



STRENGTH TRAINING SYSTEMS

BODYCRAFT 2010

PLATINUM SERIES



Functional Training Arms

- >sports specific/core training<
- >mimics free-weight feel<
- >11 adjustable positions<
- >dual arms<



Color Options

- >beautiful semi transparent acrylic<
- >your choice of 5 colors<
- >the new look of fitness<



Leg Shaping System

- >customizable positions<
- >seated leg extension<
- >seated leg curl<



Active Balance System

- >engages stabilizer muscles<
- >lock down option<
- >free weight feel<
- >patent-pending<



Seated Assist

- >no hassle range adjustment<
- >multi exercise adjustment<
- >easy grip enabled<



Double-Up

- >turns weight stack into 400lbs<
- >quick hook engagement<
- >never obsolete<

High Pulley
 1 Lat Pull Downs
 Tricep Push Downs
 Adjustable Starting Point
 Accommodates All Size Users
 Adjustable Contoured Ergonomic Back-Pad
 Provides Many Chest and Back Exercises
 Ergonomically Designed for Specific Exercises

Press - Row
 2 Advanced Abdominal Training
 Trains - Transverse Abdominals, Internal Obliques, External Obliques, Rectus Abdominis

Abs
 3 The Originator of the Cable Arms
 Mimics the Freeweight Feel of Dumbbells
 Updated Laser Cut Dual Arms
 11 Adjustable Positions Provides Unlimited Exercise Possibilities
 Functional, Sports Specific, and Core Training

Cable Arms
 4 Foot Plate for Upright Rows
 Abductor, Adductor Leg Kicks, Arm Curls, Upright Rows
 1:1 Ratio

Low Pulley
 5 Sealed Internally Lubricated Bearings
 Exceptionally Smooth Unmatched Performance
 Seated Leg Ext. Standing Leg Curl

Self-Aligning Leg
 6 Laser Cut Functional Training Arms
 4 Standard Color Options w/ Custom Colors Available
 Seated Spring Assist
 Unique Double -Up Feature for a 400lb Bench Press
 Contoured Ergonomic Back-pad

GXP

BODYCRAFT

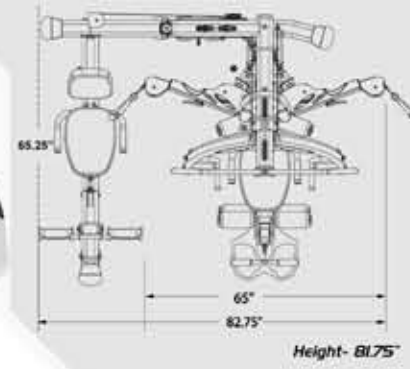

SPACE SAVING DESIGN ALLOWS PLACEMENT AGAINST A WALL

GXP shown in Satin Ice W/ Optional 2:1 ratio Leg Press/Calf

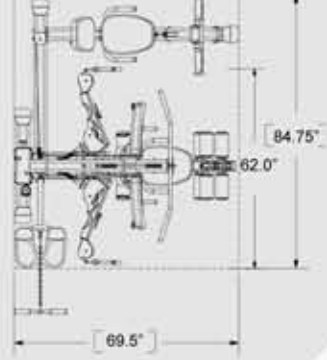

Height - 82.50"



SPACE SAVING DESIGN - LOWS PLACEMENT AGAINST A WALL



High Pulley Lat Pull Downs
Tricep Push Downs
Adjustable Starting Point
Accommodates All Size Users

Press - Row Advanced Abdominal Training
Trains - Transverse Abdominals, Internal Obliques, External Obliques, Rectus Abdominis

Abs Seated Over-head Tricep Pull
The Originator of the Cable Arms
Mimics the Freeweight Feel of Dumbbells

Cable Arms Dual Arms
11 Adjustable Positions Provides Unlimited Exercise Possibilities
Functional, Sports Specific, and Core Training

Low Pulley Foot Plate for Low Rows
Abductor, Adductor, Leg Kicks, Arm Curls, Upright Rows

Leg - Curl Simulates Freeweight Exercises
Seated Leg Ext. Seated Leg Curl
Exceptionally Smooth Unmatched Performance

Pro Laser Cut Functional Training Arms
4 Standard Color Options w/ Custom Colors Available
Sealed Internally Lubricated Bearings

Seated Spring Assist
Unique Double-Up Feature for a 400lb Bench Press
Active Balance System
Contoured Ergonomic Back-Pad
Leg Shaping System

Elite BODYCRAFT

Elite shown in Graphite W/ Optional 2:1 ratio Leg Press/Curl

Comparisons



						✓
	✓	✓	✓	✓	✓	✓
	✓	✓	✓	✓	✓	✓

In-Home Warranty : Lifetime on Everything- We Will Replace or Repair any Defect
Commercial Warranty : 10 Years Frame and Welds, 2 years Remaining Parts

Breakthrough - Patent Pending Active Balance System



The BODYCRAFT Elite is the only Strength Training System that incorporates the Active Balance System. Activate the A.B.S. for a true free-weight feel within the safety of a machine. The user is forced to balance the press arm in both push and pull exercises, which provides muscular symmetry and engages the stabilizer muscles, important for every day activities and sports.



[[WWW.BODYCRAFT.COM]]

BODYCRAFT IS A DIVISION OF RECREATION SUPPLY INC.
P.O. Box 181 SUNBURY, OH
PHONE 800 990 5556 • FAX 740 965 2449