

BODYCRAFT

SPX INDOOR TRAINING CYCLE ASSEMBLY MANUAL MODEL: VF803J

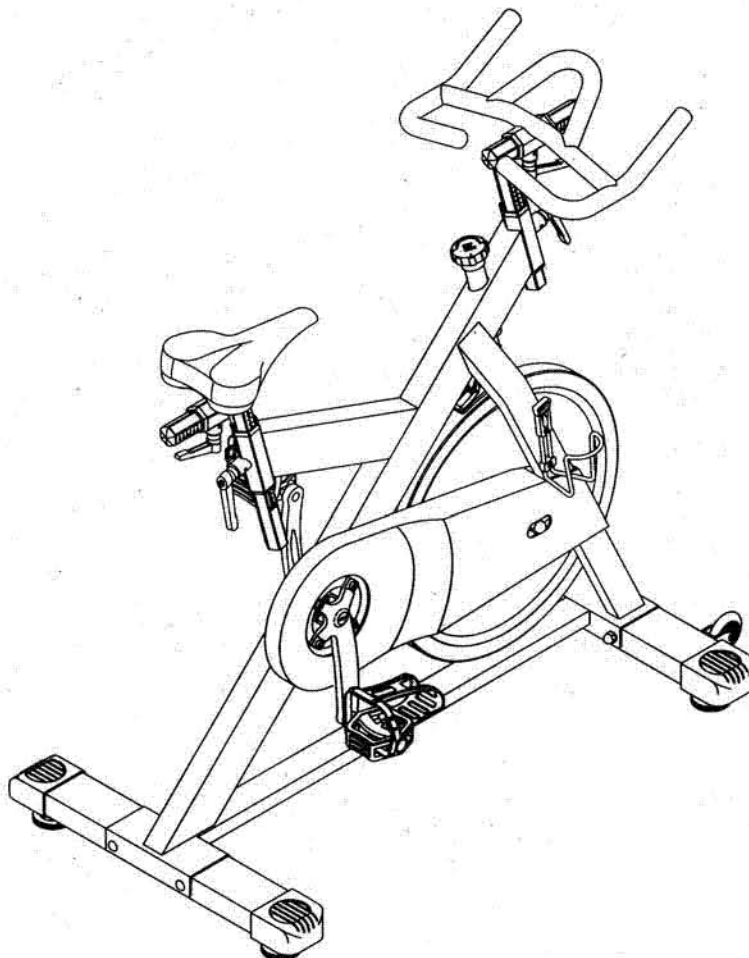

Questions?

As a quality home gym supplier we are committed to your complete satisfaction. If you have questions, or find missing or damaged parts, we will guarantee your complete satisfaction through our authorized dealer service centers or our home office customer service department. Please call your local dealer for assistance or BODYCRAFT at 800-990-5556 (9:00 AM - 5:00 PM). Our trained technicians will provide immediate assistance to you, free of charge.

We stand behind our products. Every piece, every part of this BODYCRAFT strength training system is guaranteed for as long as you own it. We will repair or replace anything that goes wrong.

*Bodycraft is a division of Recreation Supply Inc.
P. O. Box 181
Sunbury, OH 43074*

BEFORE YOU BEGIN

Congratulations and thank you for selecting the **BODYCRAFT SPX INDOOR TRAINING CYCLE**. The **SPX INDOOR TRAINING CYCLE** offers an impressive array of cardio training exercises to develop lower body muscle group of the body and tone up your cardio fitness.

Whether your goal is cardiovascular fitness, a shapely, toned body or dramatic muscle size and strength, the **SPX INDOOR TRAINING CYCLE** will help you achieve the specific results you want.

For your safety and benefits, read this manual and the accompanying literature before using the **SPX INDOOR TRAINING CYCLE**. Keep this manual for future reference. If you have additional questions, please call your local **BODYCRAFT** dealers or our customer service department at 800-990-5556 Monday through Friday, 9 a.m. until 5 p.m. Eastern Time.

IMPORTANT SAFETY NOTES

There is a risk assumed by individuals who use this type of equipment. Before beginning this or any other exercise program consult your physician. This is especially important for individuals over the age of 35 or persons with pre-existing health problems. Recreation Supply, Inc. assumes no responsibility for personal injury or property damage sustained by or through use of this product.

1. This product must be assembled on a flat, level surface to assure its proper function.
2. Inspect and tighten all parts before every use. Replace any worn parts immediately. Failure to do so may result in serious injury.
3. Keep children away from the **SPX INDOOR TRAINING CYCLE** at all times.
4. Keep your hands away from flywheel and all moving parts.
5. When adjusting the seat post and handlebar post slowly to avoid your fingers not pinching by seat post or handlebar stem and seat is tighten by Lock Lever. If not, the seat may slip and cause injury.
6. Wear soft jogging shoes and put your foot as far forward as you can to toe-clip, use two hands to adjust the strap of pedal to tighten.
7. Do Not raised Handlebar Stem and Seat Post above SAFETY LINE. Failure to do so may result in serious injury.
8. If unsure about the proper use of the **SPX INDOOR TRAINING CYCLE** cardio training system call your local **BODYCRAFT** dealer or our customer service department at 800-990-5556.

EXPLODED 1

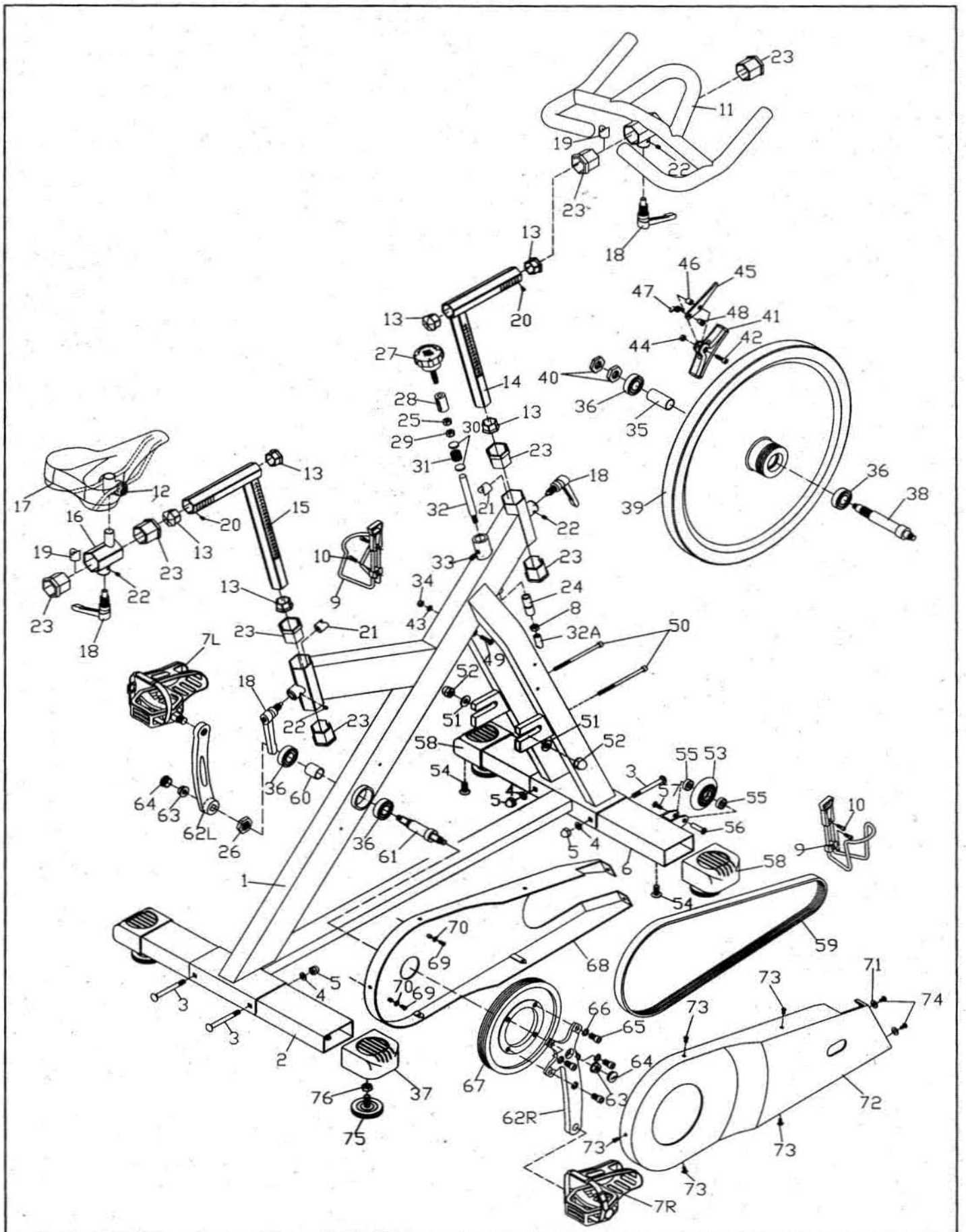

EXPLODED 2

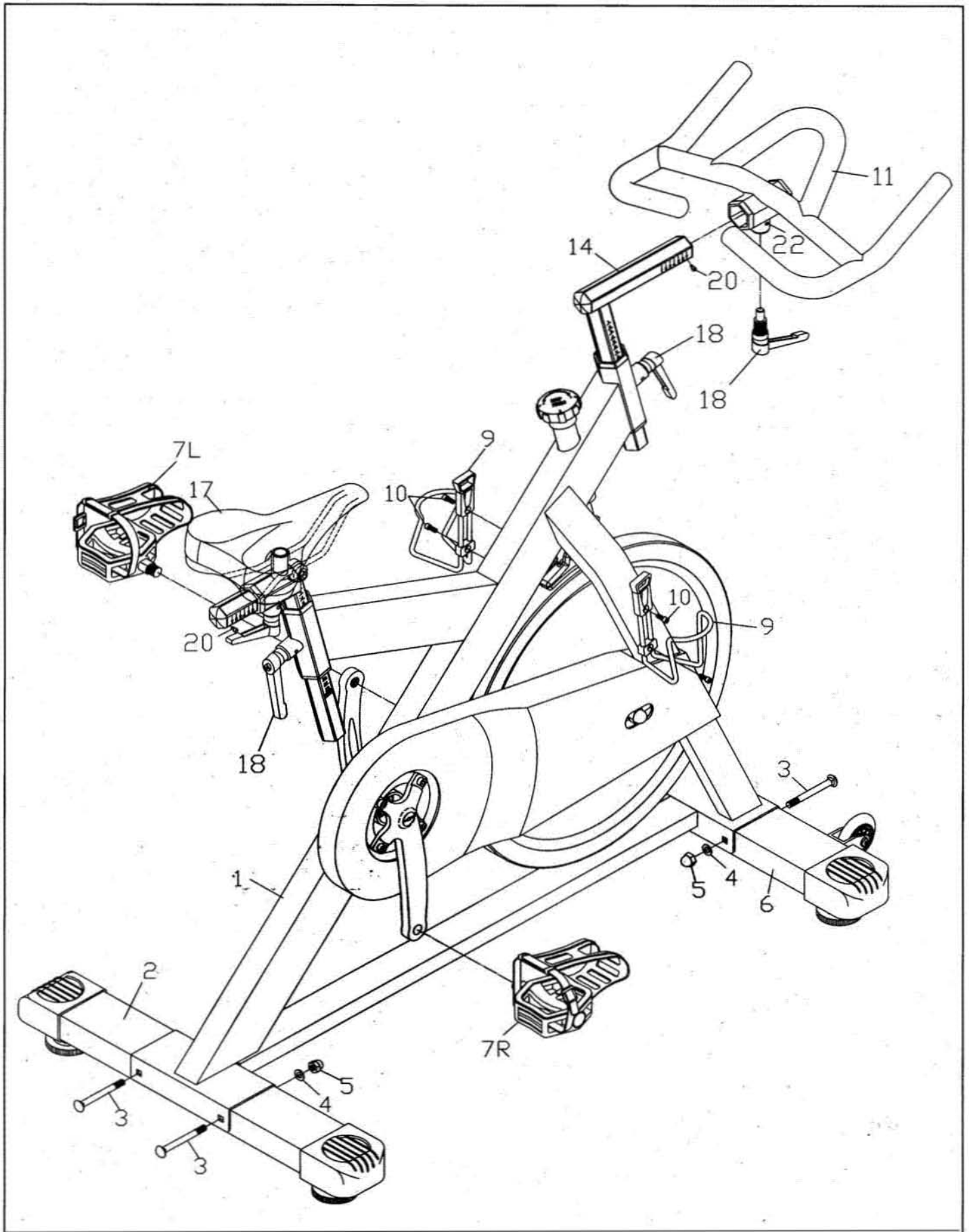

NO.	DESCRIPTION	QTY.
1	Main Frame	1
2	Rear Stabilizer	1
3	M8 X 4" Domed Bolt	4
4	M8 Washer	4
5	M8 Domed Nut	4
6	Front Stabilizer	1
7L(R)	Pedal	1
8	M8 Nut	1
9	Bottle Cage	2
10	Bottle Cage Fixed Screw	4
11	Handle Bar	1
12	Seat Clamp	1
13	Busing for Handle Stem and Seat Post	6
14	Stainless Steel Handle Bar Stem	1
15	Stainless Steel Seat Post	1
16	Seat Sliding Housing	1
17	Seat (Saddle)	1
18	Lock Lever	4
19	23L Lock Nut	2
20	V Lock fixed Screw	2
21	V Block	2
22	V Block fixed Screw	4
23	Plastic Sleeve	8
24	Nylon Sleeve	1
25	3/8" Nut	1
26	M20 Nut	1
27	Adj. Knob	1
28	34L Busing	1
29	M8 Lock Nut	1
30	Round Plate	2
31	20L Spring	1
32	Axle	1
32A	Lower Stud.	1
33	M8 X 5/16" Guide Screw	1
34	M6 Nut	1
35	Spacer	1
36	6004ZZ Bearing	4
37	Rear Stabilizer End Cap	2
38	Flywheel Axle	1
39	Flywheel	1
40	M17 X 5/16" Lock Nut	2

