

# BODYCRAFT

## EXP SERIES™

### DFT Functional Trainer



For the Owner's Manual  
Assembly STEPS in  
**FULL COLOR**  
& additional information,  
scan this QR code.

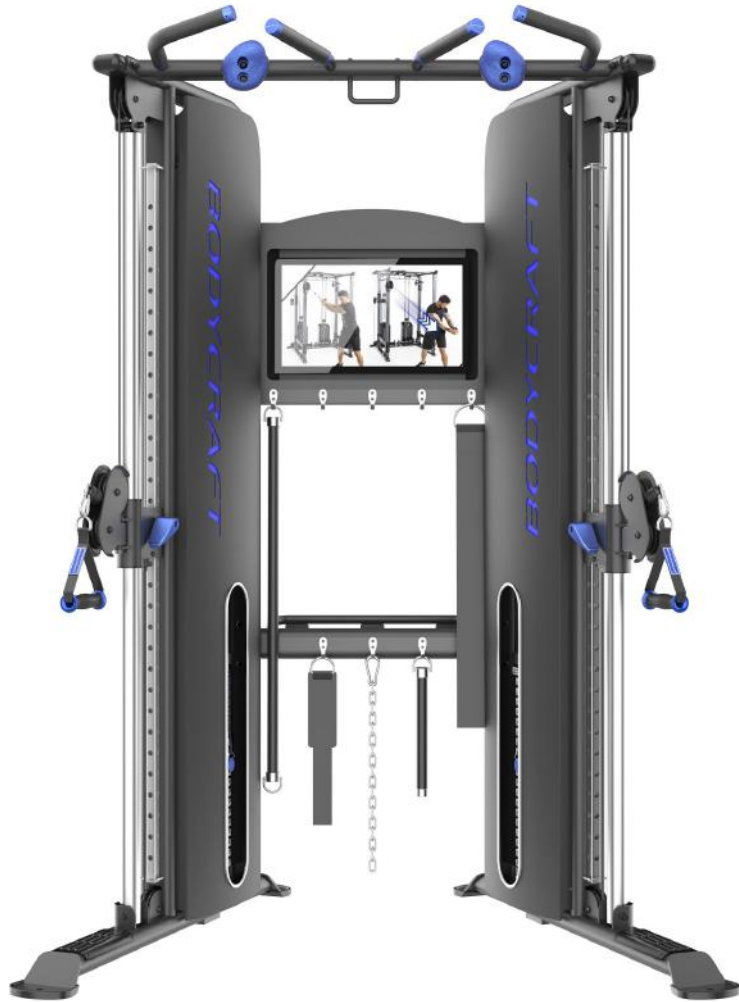

Base Serial Number: \_\_\_\_\_

Purchased Date: \_\_\_ / \_\_\_ / \_\_\_\_\_

Dealer's Name: \_\_\_\_\_

Please register your products at:

<https://www.bodycraft.com/product-registration/>



## Owner's Manual

DFT\_OM v1.2



WWW.BODYCRAFT.COM



800-990-5556



SERVICE@BODYCRAFT.COM

## ***Congratulations and Welcome to the BODYCRAFT Family***

***Thank you for selecting BODYCRAFT. Your choice reflects a wise investment in you and your facility. We hope you use it for many healthy years!***

BODYCRAFT offers a complete array of high-quality fitness equipment. Please refer to our website at [www.bodycraft.com](http://www.bodycraft.com) to view more ways to enhance your lifestyle.

Your BODYCRAFT machine has all the quality and design elements to make your workout extremely efficient and comfortable. Your new unit is a serious strength training machine that will keep you motivated, challenged and within reach of your fitness goals. Strength & cardiovascular training is vital for all ages which will provide an effective workout, producing results that will encourage you to reach your fitness goals and maintain the body you have always wanted.

***Spending 15 to 30 minutes a day, three times a week, is all you need to start seeing the benefits of a regular exercise program.***

As a premium exercise equipment manufacturer, we are committed to your complete satisfaction. If you have questions, suggestions or find missing or damaged parts, we guarantee your complete satisfaction through our authorized dealer network or by contacting us directly. Please call your local dealer or BODYCRAFT.

BODYCRAFT (a division of Recreation Supply, Inc.)  
7699 Green Meadows Dr.  
Lewis Center, OH 43035

**Phone:** 800-990-5556 9 am - 5 pm EST **Email:** [service@bodycraft.com](mailto:service@bodycraft.com)

Proof of purchase must be supplied to validate warranty and the product must have been registered with BODYCRAFT via online at [www.bodycraft.com](http://www.bodycraft.com) or by calling 800-990-5556 or 740-965-2442 M-F 9 a.m. - 5 p.m. EST.

For parts orders, owner's manuals, software update files, exercise guides and contact information scan this QR code.

Or go to:

<https://www.bodycraft.com/customer-support>

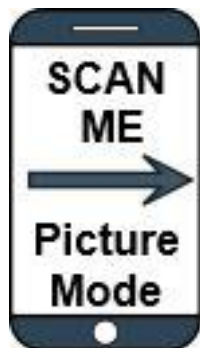

## Table of Contents, DFT



**NOTE:** When you have downloaded the Owner's Manual into a PDF reader, go directly to the desired page by touching any **BLUE** line in this Table of Contents.

<b>Product Safety Information</b>	<b>Page</b>
Product Safety .....	4
Important Notes, Recommended Tools & Cleaners .....	5
Warning Labels, Maintenance Schedule - Details.....	6
Warning Labels, Maintenance Schedule - Placements .....	7
<b>Product Overview</b>	
Machine Dimensions & Recommended Training Area .....	8 - 9
Weight Stack & Pulley Ratios .....	10
Assembly Parts & Hardware List.....	11 - 12
Shipping Boxes Dims & What's Inside.....	13
<b>Product Assembly</b>	
Pre-Assembly Tips .....	14
STEP 1 - STEP 14.....	15 - 28
STEP 15 - Final Assembly Clean Up & Polish.....	29
<b>Maintenance &amp; Repair</b>	
Routine Schedule .....	30
General & Cable Inspections .....	31
Lubrication Maintenance .....	32
Strength Cable Wear Indicators .....	33
Detailed Parts Exploded View.....	34 - 35
Detailed Parts, Cable Routing .....	36
Detailed Parts List .....	37 - 39
Required Info BEFORE Initiating a Service Case .....	40
<b>Warranty</b>	
Product Warranty .....	41
Product Warranty Registration .....	42
Contact Us Information .....	43



***There is a risk assumed by individuals who use this type of equipment. A moment's lack of attention can result in an accident, as can failure to observe certain simple safety precautions.***

***Read, study and understand the Assembly Instructions and all the warning labels on this product. Furthermore, it is recommended to familiarize yourself and others with the proper operation and workout recommendations for this BODYCRAFT product prior to use.***

- Before beginning this or any other exercise program, consult your physician. This is especially important for individuals over the age of 35 or persons with preexisting health problems. Recreation Supply, Inc. assumes no responsibility for personal injury or property damage sustained by or through use of this product.
- Exercise with care to avoid injury. Do not attempt to lift more weight than you can control safely.
- This product must be assembled on a flat, level surface to assure its proper function.
- Clean pads and frame on a regular basis. We recommend warm, soapy water. Do not use harsh or abrasive chemicals.
- Inspect and tighten all parts before every use. Replace any worn parts immediately. Failure to do so may result in serious injury.
- Keep children away from any BODYCRAFT strength machines at all times.
- Keep your hands away from cables and pulleys during operation, other than the designated handles.
- Keep hands, limbs, loose clothing and long hair well out of the way of moving parts.
- Make certain all cables are seated within the pulleys before every use. Frayed or worn cables can be dangerous and may cause injury. Periodically check the cable for any indication of wear.
- Inspect the unit for any sign of wear on parts, hardware becoming loose or cracks on welds. If a problem is found, do not use or allow the machine to be used until the defective part is repaired or replaced.
- It is imperative that you retain this Assembly Instructions and be sure all warning labels are legible and intact. Replacement Assembly Instructions and labels are available from BODYCRAFT. If you are unsure about the proper use of the BODYCRAFT strength machine call your local BODYCRAFT dealer or our Customer Service Department. Contact BODYCRAFT at 800-990-5556 or [support@bodycraft.com](mailto:support@bodycraft.com)



## Important Notes, Recommended Tools & Cleaners, DFT

### Important Notes and Tips:

1. Before assembly, read all instructions thoroughly and preview diagrams to help make the installation easier.
2. Make sure all parts are accounted for and in proper condition before beginning assembly. See the parts list.
3. Be cautious not to damage the flooring when assembling. Place a protectant down such as a rubber mat or shipping blanket.
4. Let plastics and weight stacks acclimate to room temperature before you begin assembly.
5. Two people are recommended for the safe assembly of this equipment.
6. Insert all bolts in the same direction when possible. Do not tighten until instructed.
7. Carefully install plastic caps using a rubber mallet.
8. When measuring bolt lengths, only measure the *shank*.
9. When the installation is complete, be sure to regularly check for rust or damage, and perform preventative maintenance.

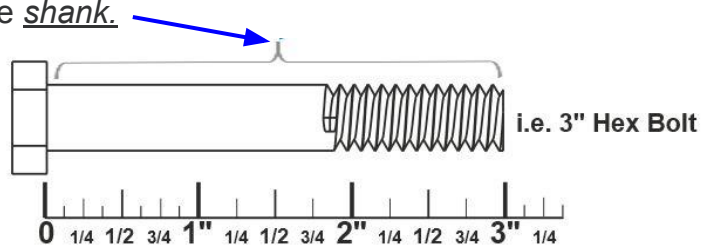

### THE FOLLOWING TOOLS ARE RECOMMENDED FOR ASSEMBLY:



**SOCKET SET 3/8 DRIVE & 6" EXT**  
(Only 9/16 Socket is needed)



**OPEN, CLOSED & ADJUSTABLE WRENCHES**  
(Only 9/16 is needed)



**TORQUE WRENCH 3/8 DRIVE**  
(w/ 4mm, 7/32 Hex Bit Socket)



**RUBBER MALLET & ALLEN WRENCH SET**  
(Only 4mm, 7/32 are needed)

### THE FOLLOWING IS RECOMMENDED FOR CLEANING:



**MILD CLEANING SOLUTION**



**100% COTTON CLEANING CLOTHS**

**TIP ON FRAME ONLY:** For extra protection from fingerprints, sweat stains or just plain dirt, apply an automotive grade cleaner wax if desired. Also makes future cleaning easier.



**(Do Not Use on the Upholstery)**



Carefully read ALL warning, caution & maintenance schedule labels



(104)



(108)



(113)



(105)



(109)



(114)



(106)



(110)

MAINTENANCE SCHEDULE				
This checklist needs to be followed before any user starts to exercise. Please replace all parts at first signs of wear or damage. Do not use machine until repaired as needed.				
	DAILY	WEEKLY	MONTHLY	12-MONTHS
<b>Upholstery</b> - Wipe down and dry. - Clean and condition.	X	X		
<b>Bolts, Nuts &amp; Fasteners</b> - Visually check they are secure & tighten if needed. - Tighten per Torque Specs (Semi-Annually if needed)	X			X
<b>Cables</b> - Visually check for any unusual bends, kinking, fraying plastic cover or ends coming loose. - Adjust cable tension and tighten the locking nut at weight stack.	X		X	
<b>Guide Rods &amp; Seat Sleeves</b> - Clean & Lubricate w/ virgin Silicone or Teflon lube.			X	
<b>Linear Bearing Guide Rods</b> - Clean & Lubricate with Teflon (PTFE) grease.			X	
<b>Tightening Knobs</b>	X			
<b>Locking Pins</b>	X			
<b>Weight Stack Pins</b>	X			
<b>Pop Pins / Springs</b> - Check all for functionality.	X			
<b>Warning Labels</b>	X			
<b>Anti-Skid Surfaces</b>	X			
<b>Hand Grips &amp; Rollers</b> - Inspect all above items for wear or if missing.	X			
<b>Frame &amp; Chrome</b> - Clean and dry. - Clean and Wax.			X	X

Additional information, step-by-step processes, and more detailed instructions, refer to the machines Owner's Manual or contact BODYCRAFT Customer Support.  
**800-990-5556** v1.6

(111)



(107)

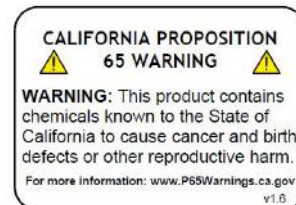

(112)

NOTE: Labels are not to scale

# Warning Labels, Maintenance Schedule & Serial Number Placement, DFT



Carefully read ALL warning, caution & maintenance schedule labels

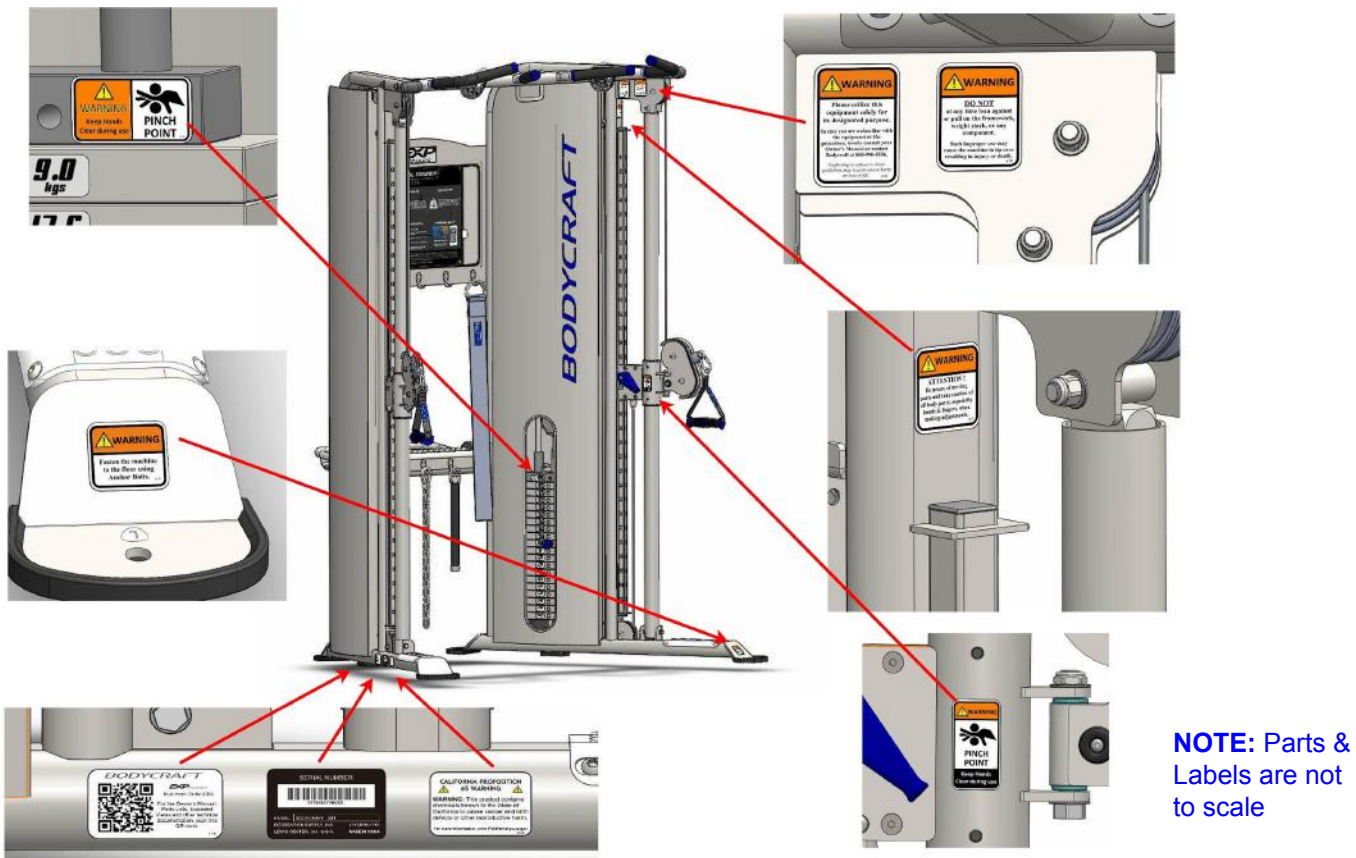

NOTE: Parts & Labels are not to scale



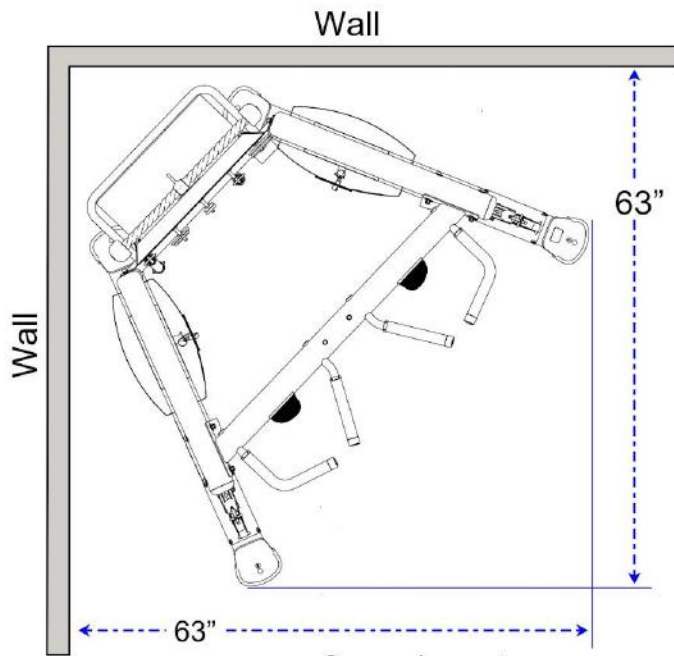

Corner Layout  
63" L x 63" W x 84.3" H

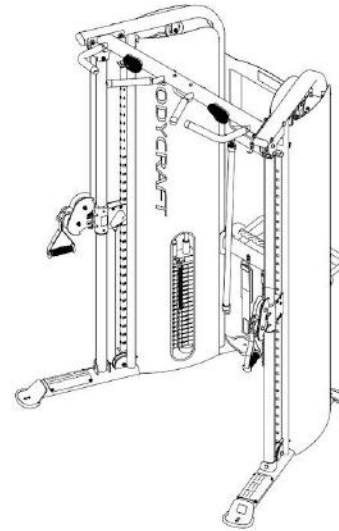

### DFT Functional Trainer Overall Dimensions

62.5 L x 49.7" W x 84.3" H  
(158.7 cm L x 126.4 cm W x 214.1 cm H)

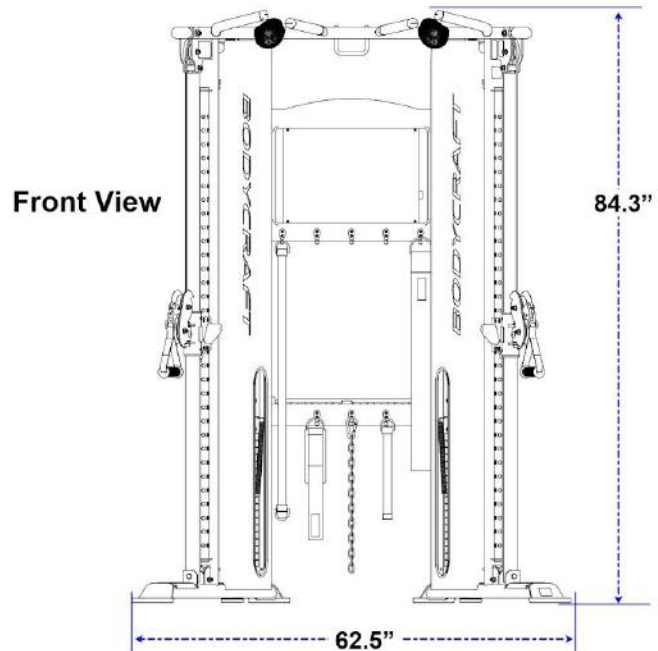
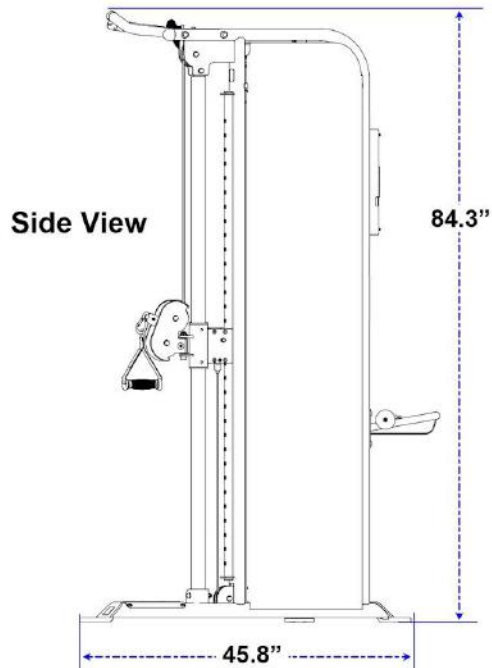
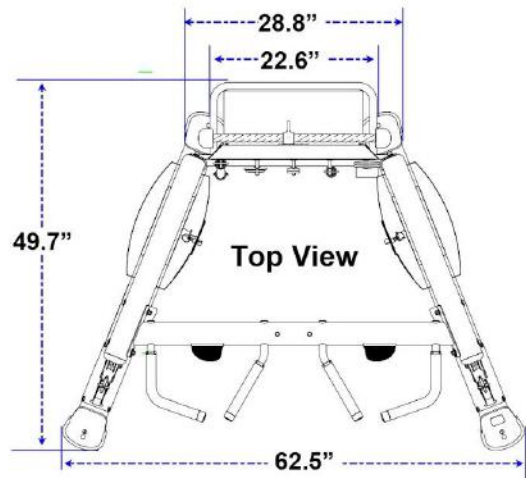



## Recommended Training Area, DFT

### Recommended Training Area (Normal)

- w/ FID Bench Area @ 48"
- w/ above Pull-Up Bars @ 24"

**110.5" L x 103.7" W x 108.3" H**  
(280.7 cm L x 263.4 cm W x 275.1 cm)

**Back: 6" (15.3 cm)**

**Front: 48" (122 cm)**

**Right & Left Sides: 24" (61 cm)**

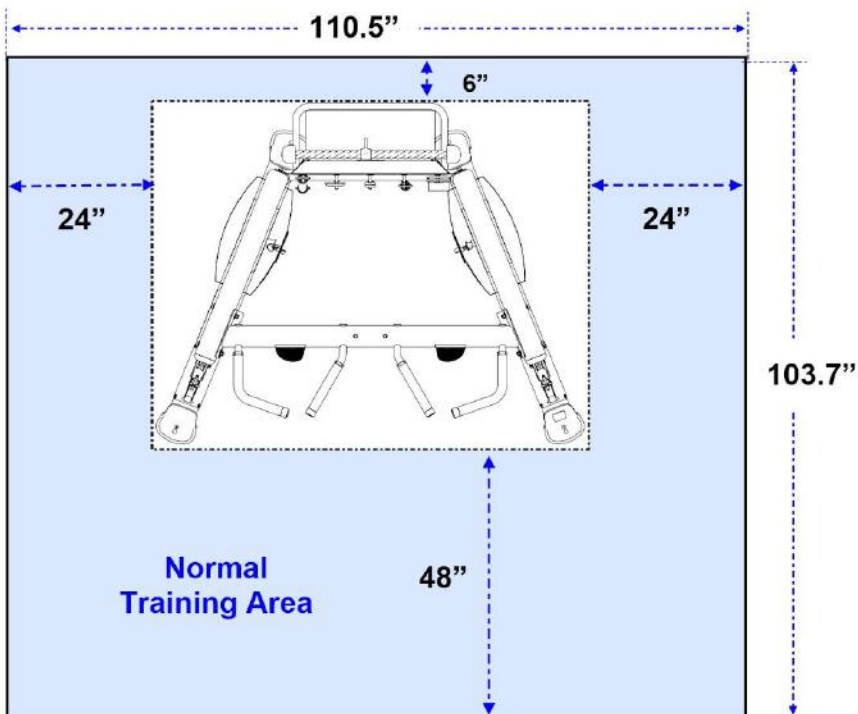

ADA Compliant

**For ADA Compliance under #1004 Exercise Machines and Equipment:**

Minimum of 36" for entry, use & exit of machine required. Add 12" in the Training Area where needed.

### Recommended Training Area (Max)

- w/ Cable Travel @ 77"
- w/ Single Handle & Clip @ 11"
- w/ above Pull-Up Bars @ 24"

**143.7" L x 134.5" W x 108.3" H**  
(365 cm L x 341.6 cm W x 275.1 cm)

**Back: 6" (15.3 cm)**

**Front: 88" (223.5 cm)**

**Right & Left Sides: 36" (91.4 cm)**

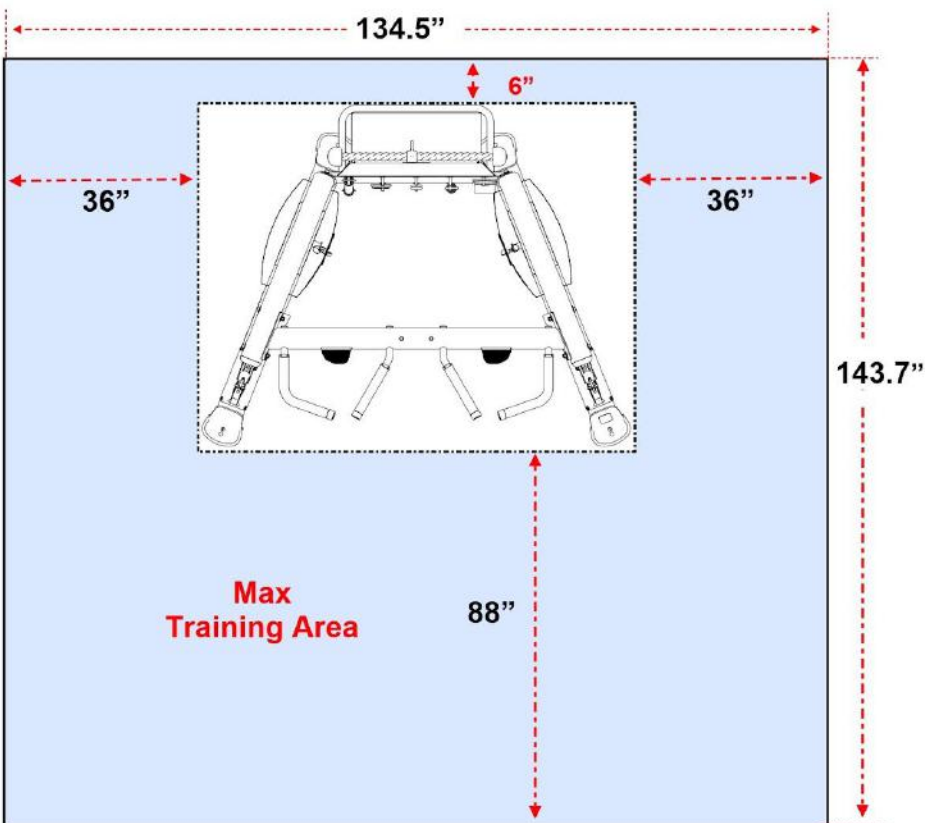

# Weight Stack & Pulley Ratios, DFT

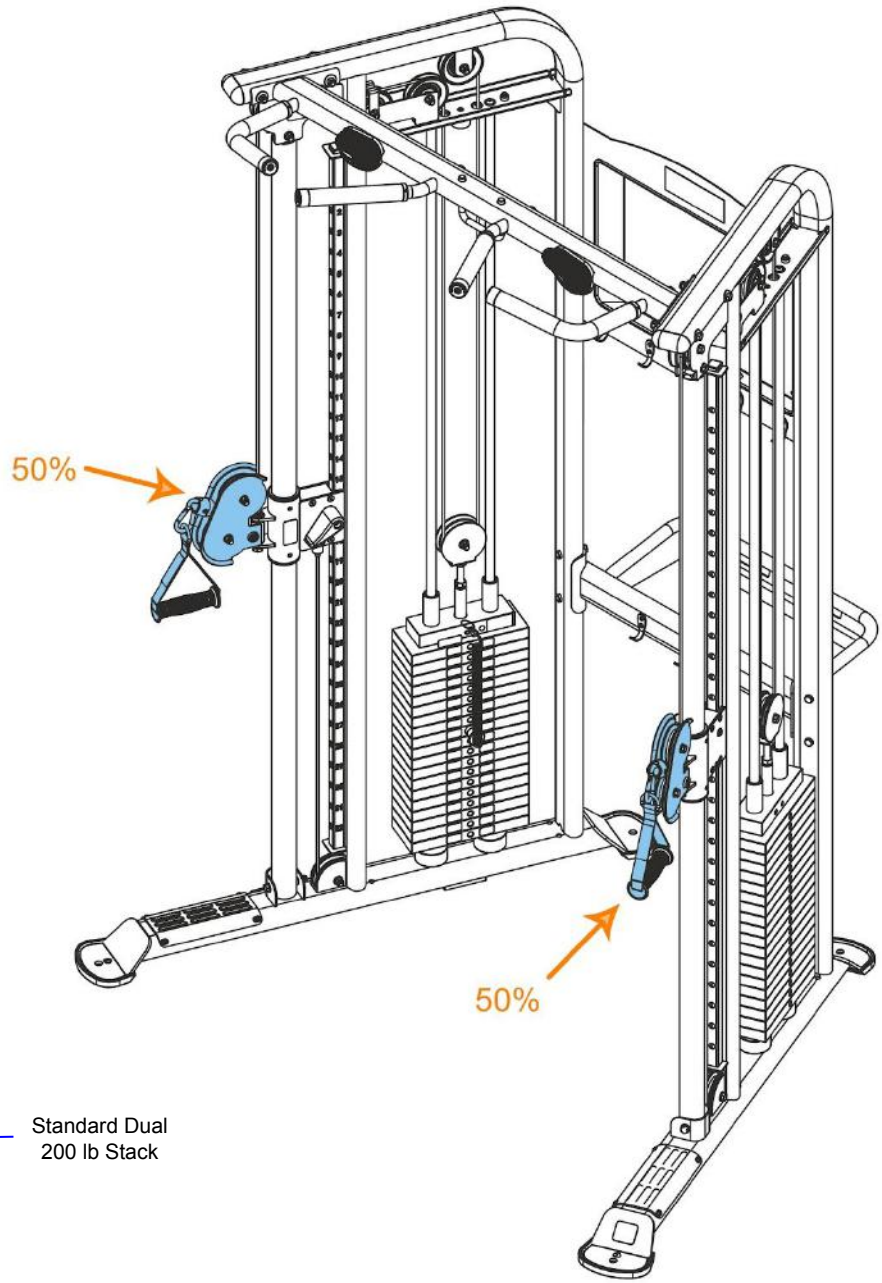

Plate Number	Weight at Stack	Weight at Pulley 50%
1	10	5
2	20	10
3	30	15
4	40	20
5	50	25
6	60	30
7	70	35
8	80	40
9	90	45
10	100	50
11	110	55
12	120	60
13	130	65
14	140	70
15	150	75
16	160	80
17	170	85
18	180	90
19	190	95
20	200	100
21	210	105
22	220	110
23	230	115
24	240	120
25	250	125

Standard Dual  
200 lb Stack

Upgraded Dual  
250 lb Stack

**NOTE:** Weights are approximate

Part #	Assembly Parts List	QTY
DFT-001-ASM	Frame, Main, Left - Assembly	1
DFT-002-ASM	Frame, Main, Right - Assembly	1
DFT-009-ASM	Frame, Connecting, Bottom w/ Accessory Tray - Assembly	1
DFT-010-ASM	Chinbar w/ Multi-Grip Bars & Rock Climbing Grips - Assembly	1
DFT-012-ASM	Frame, Connecting, Top w/ Bookrack & Accessory Holders - Assembly	1
DFT-013	Pulley Block, Single, w/ Threaded Shaft 1/2" OD	2
DFT-015-ASM	Weight Stack Shroud Cover, Front, Left - Assembly	1
DFT-016-ASM	Weight Stack Shroud Cover, Front, Right - Assembly	1
DFT-017	Weight Stack Shroud Cover, Rear, Left	1
DFT-018	Weight Stack Shroud Cover, Rear, Right	1
DFT-021	Weight Plate, 10lbs (4.5kg), Standard 200 lb Weight Stack 19 each Per Side	38
DFT-21B-OPT	OPTION - Weight Plate, 15 lbs (6.8kg), Upgraded 250 lb Weight Stack w/ 18 each #21 Plates	20
DFT-024-ASM	Top Plate- Assembly	2
DFT-025	Selector Pin w/ Lanyard, Aluminum - BLUE	2
DFT-030	Snap Hook	4
DFT-039	Pulley, Nylon, 90mm (3-1/2") x ̅26mm ID	2
DFT-056	Accessory, Chain, 19.7" L	2
DFT-064	Sticker Set for Weight Stack, for 200 lb or 250 lb Stacks	2
DFT-065	Accessory, Long Strap, 1,300mm L	1
DFT-066	Accessory, Ankle Cuff (Leg Strap)	1
DFT-067	Accessory, Long Bar, 1,010mm L	1
DFT-068	Accessory, Short Bar, 365mm L	1
DFT-069	Accessory, Single Handle	2
DFT-070	Accessory, Nylon Triceps Rope	1
DFT-102	Silicone Lube Bottle, for Guide Rods	1

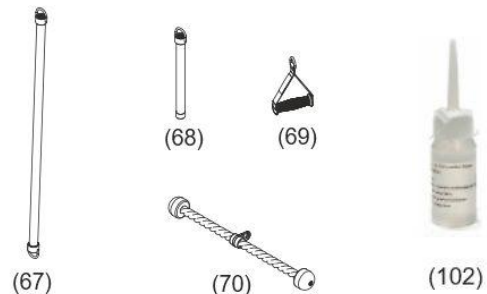
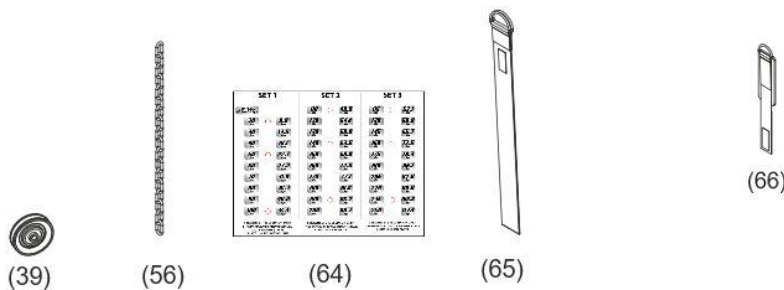
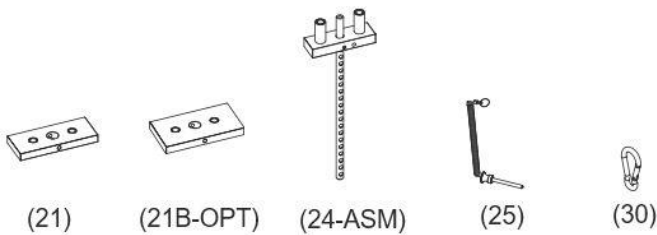
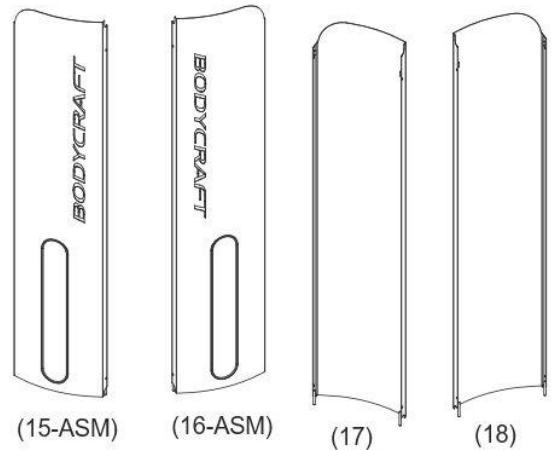
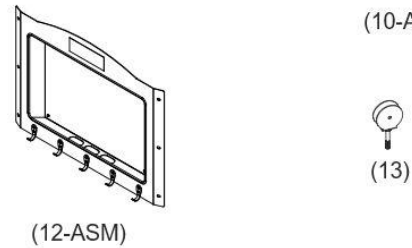
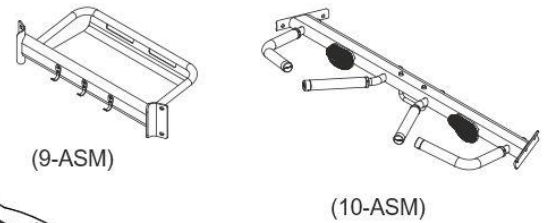
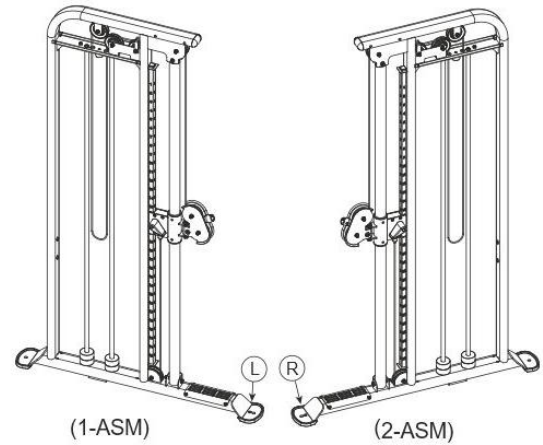

**NOTE:** For a complete service parts list, please refer to the detailed parts list & exploded view at the rear of this manual.

Part #	Assembly Hardware	QTY
DFT-071	Bolt, Hex Head, 3/8" x 1" L	4
DFT-072	Bolt, Hex Head, 3/8" x 2" L	2
DFT-075	Bolt, Hex Head, 3/8" x 4" L	4
DFT-082	Screw, Hex Recessed Flat Head, M6 x 12mm L	6
DFT-087	Washer, Arc, 3/8"	8
DFT-088	Washer, Spring, φ6mm	6
DFT-089	Washer, Spring, 1/2"	2
DFT-090	Washer, Spring, 3/8"	4
DFT-091	Washer, Flat, φ6mm	6
DFT-093	Washer, Flat, 3/8"	8
DFT-096	Nut, Nylon Lock, 3/8"	6
DFT-098	Nut, Hex, 1/2"	2
DFT-099	Wrench, Hex, 4mm	1
DFT-100	Wrench, Hex, 7/32"	1

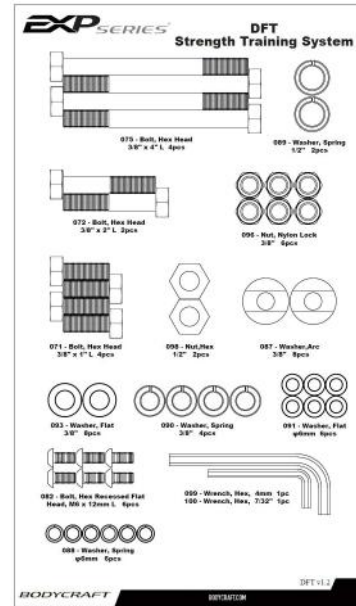

(71)

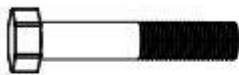

(72)

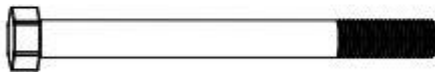

(75)



(82)



(87)



(88)



(89)



(90)



(91)



(93)



(96)



(98)

**NOTE:** Parts are not to scale



## Shipping Boxes & What's Inside Each One, DFT

### Large Box 1 of 3

**Net Weight:** 157 lbs (71 KG)

**Gross Weight:** 177 lbs (80 KG)

**Box Size:** 84" L x 52" W x 7" H  
(2,115mm L x 1,310mm W x 170mm H)



### Large Box 2 of 3

**Net Weight:** 148 lbs ( 67KG)

**Gross Weight:** 168 lbs ( 76KG)

**Box Size:** 84" L x 52" W x 7" H  
(2,115mm L x 1,310mm W x 170mm H)



### Large Box 3 of 3

**Net Weight:** 115 lbs (52 KG)

**Gross Weight:** 128 lbs (58 KG)

**Box Size:** 84" L x 19" W x 12" H  
(2,125mm L x 470mm W x 280mm H)



### Small Boxes 8 ea. (total)

#### Standard 200 lb Stacks

2 boxes, 4ea of 10 lb plates = **40 lbs per CWP10(4) box**

6 boxes, 5ea of 10 lb plates = **50 lbs per CWP10(5) box**

#### Upgraded to 250 lb Stacks?

2 boxes, 4ea of 10 lb plates = **40 lbs per CWP10(4) box**

2 boxes, 5ea of 10 lb plates = **50 lbs per CWP10(5) box**

4 boxes, 5ea of 15 lb plates = **75 lbs per CWP15(5) box**



**CWP10(4) Size:** 11" L x 5" W x 5" H ea.  
(264mm L x 110mm W x 115mm H)

**CWP10(5) Size:** 11" L x 5" W x 6" H ea.  
(264mm L x 110mm W x 140mm H)

**CWP15(5) Size:** 13" L x 6" W x 6" H ea.  
(310mm L x 130mm W x 140mm H)

BODYCRAFT reserves the right to make improvements at any time which may affect color, parts, materials, size, weight, or any other aspect.

### PREASSEMBLY TIP #1 – “Stage Right”.

During the assembly process we will be stating Right, Left, Front, Back, Top, or Bottom. These all are in the perspective of the user in the machine facing outward with feet on the ground.

See below images as examples.



**STAGE RIGHT DEFINITION:** Both “Stage Right” or “Stage Left” are from the viewpoint of the actor facing outward from the stage.



### PREASSEMBLY TIP #2 – Unpackaging & organizing.

The best practice in assembly is to take all the parts out of the boxes & bags and line up in order of assembly. This enables a mindset of what you will be assembling, their physical sizes and what challenges you might face BEFORE you begin.



### PREASSEMBLY TIP #3 – Keep hardware loose until asked to tighten.

During the assembly, hardware needs to be finger tight until the STEPS of “Torque Time”. This will ensure sub-frame and other parts will easily fit together and not strip out bolt threads during assembly.

## STEP 1: Install Connecting Frames to Rt & Lt Main Frames



Please Hand Tighten All Frame Nuts & Bolts Until STEP 11

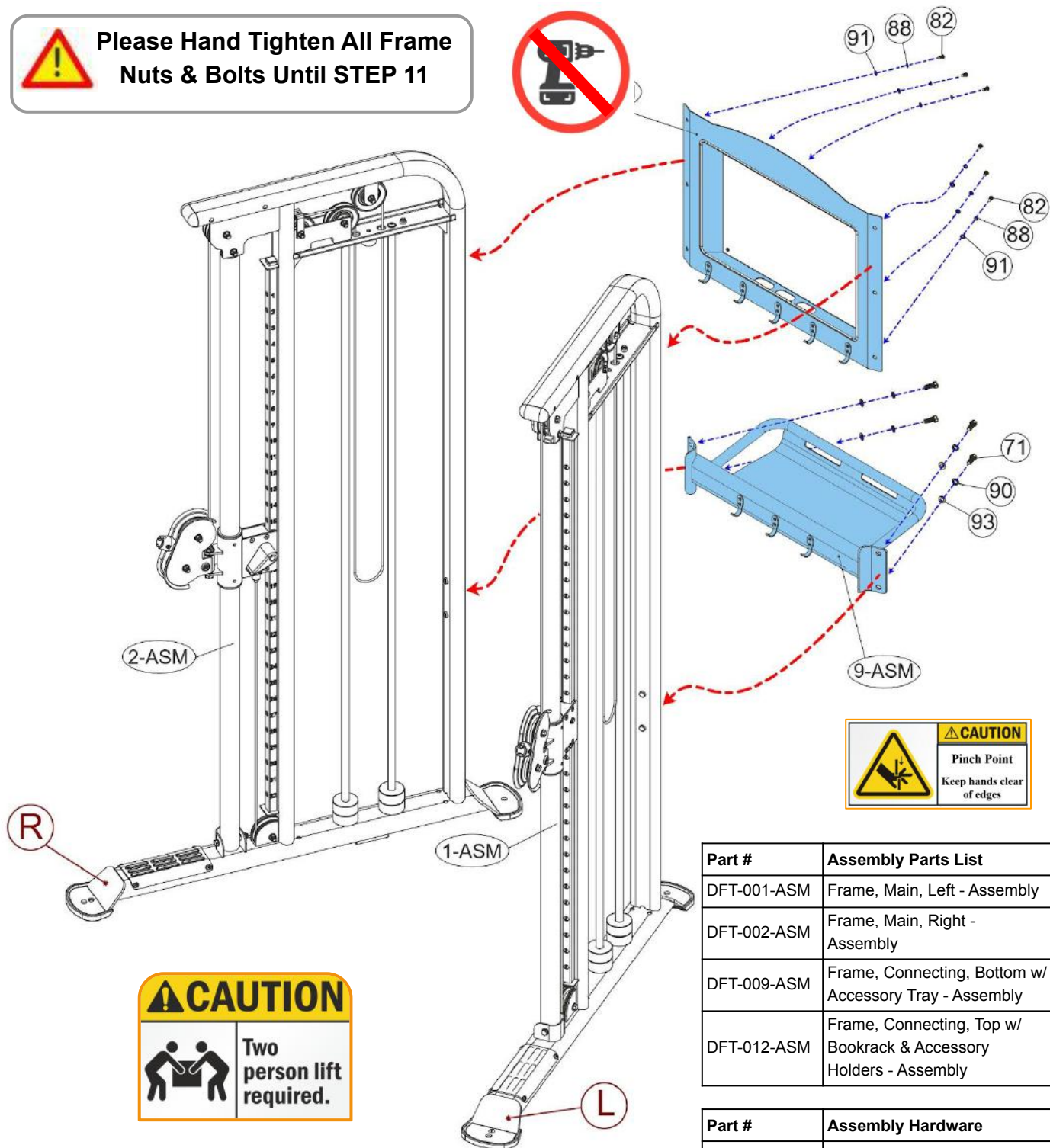

Part #	Assembly Parts List	QTY
DFT-001-ASM	Frame, Main, Left - Assembly	1
DFT-002-ASM	Frame, Main, Right - Assembly	1
DFT-009-ASM	Frame, Connecting, Bottom w/ Accessory Tray - Assembly	1
DFT-012-ASM	Frame, Connecting, Top w/ Bookrack & Accessory Holders - Assembly	1

Part #	Assembly Hardware	QTY
DFT-071	Bolt, Hex Head, 3/8" x 1" L	4
DFT-082	Screw, Hex Recessed Flat Head, M6 x 12mm L	6
DFT-088	Washer, Spring, $\phi$ 6mm	6
DFT-090	Washer, Spring, 3/8"	4
DFT-091	Washer, Flat, $\phi$ 6mm	6
DFT-093	Washer, Flat, 3/8"	4

### View Keys

**Red dotted (large):** Structural parts assembled direction.

**Red dotted (med):** Sub-parts assembled direction.

**Blue dotted lines (small):** Hardware assembled direction.

**Orange (med):** Cables are normally black, but easier to see in color.





## STEP 2: Install the Chinbar



Please Hand Tighten All Frame Nuts & Bolts Until STEP 11

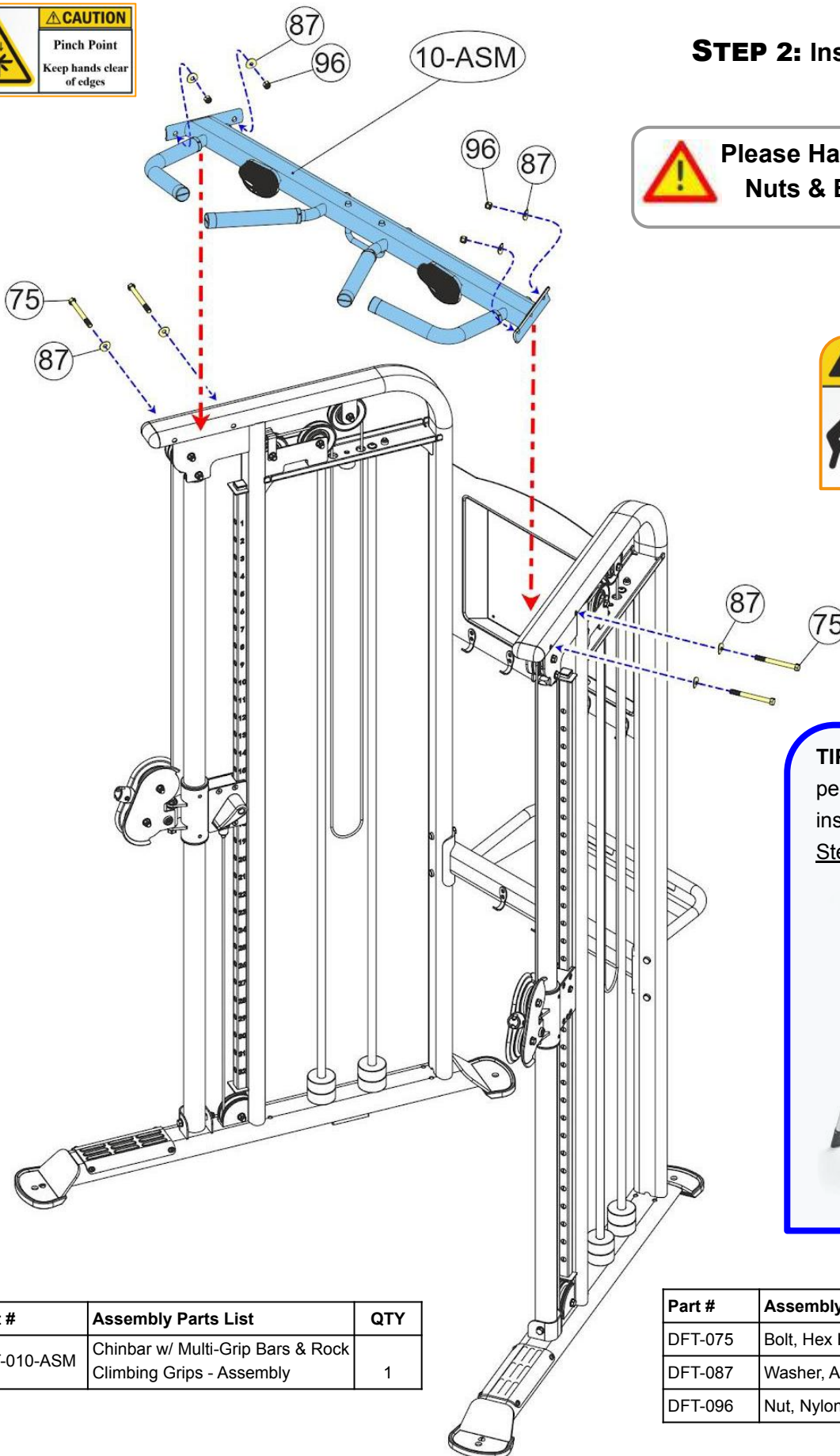

**TIP:** Recommend two people doing the STEP 2 install, with one using a Step ladder.



Part #	Assembly Parts List	QTY
DFT-010-ASM	Chinbar w/ Multi-Grip Bars & Rock Climbing Grips - Assembly	1

Part #	Assembly Hardware	QTY
DFT-075	Bolt, Hex Head, 3/8" x 4" L	4
DFT-087	Washer, Arc, 3/8"	8
DFT-096	Nut, Nylon Lock, 3/8"	4



**STEP 3: Left Side Main Frame, Removal of Pre-Installed Hardware & Top Guide Rod Holder**

Remove in the order of **A-B-C**

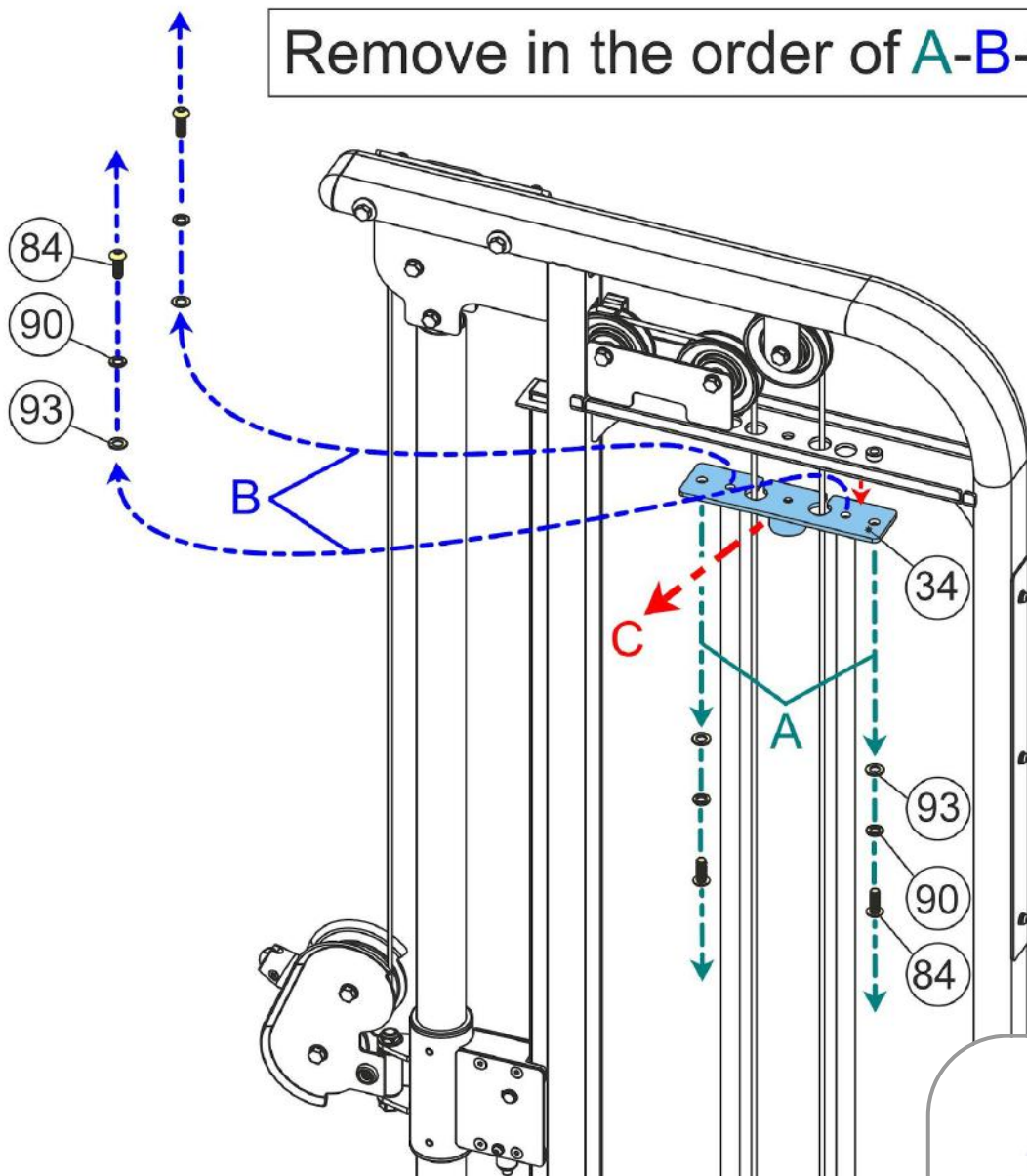

**Recommended Tool:**

(100)  
7/32 ALLEN (HEX)  
WRENCH

Left Side Main Frame

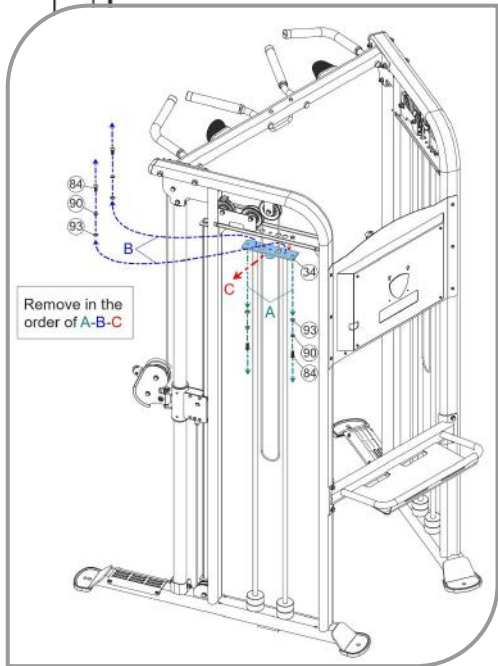

Part #	Pre-Installed Part & Hardware List	QTY
DFT-034	Top Guide Rod Holder Plate	1
DFT-084	Screw, Hex Recessed Flat Head, 3/8" x 1" L	4
DFT-090	Washer, Spring, 3/8"	4
DFT-093	Washer, Flat, 3/8"	4

**STEP 4: Left Side Main Frame, Lube Guide Rods, Install Weight Plates & Top Plate-ASM**

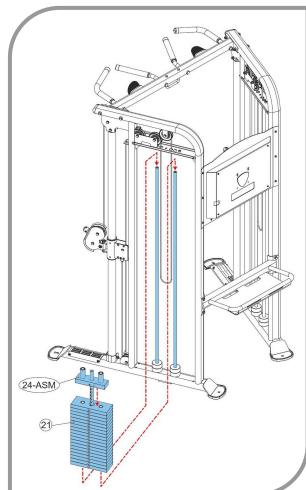

Left Side Main Frame

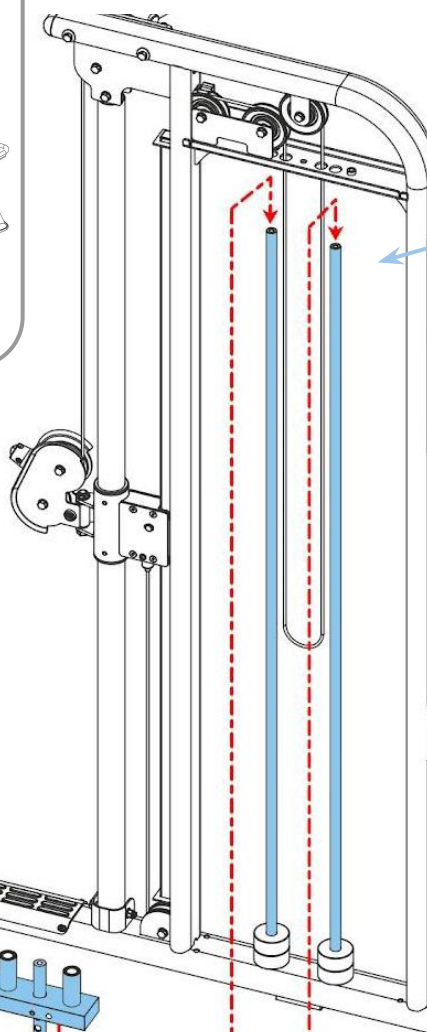

100% PURE SILICONE LUBE



100% COTTON CLEANING CLOTH

**NOTE:** Lightly lubing the Guide Rods is a great practice to do at this STEP, but also during scheduled times for preventive maintenance measure.

- Doing this before the weight stack goes on and blocks the potential “dry” part of the Guide Rods, ensures they are lubed.
- Ensures that the Weight Plates internal bushing get a “break-in” lube for a quiet & longer life operation.
- Add protection to the Guide Rods (6) from future potential surface rust in the higher humidity environments.



**Standard 200 lb stack use the following:**

- 1 box, 4ea of 10 lb plates = **40 lbs per CWP10(4) box**
- 3 box, 5ea of 10 lb plates = **50 lbs per CWP10(5) box**

**Upgraded to 250 lb stack use the following:**

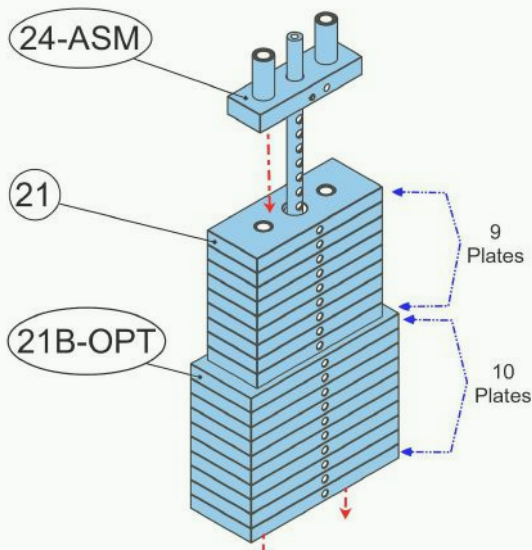

- 1 box, 4ea of 10 lb plates = **40 lbs per CWP10(4) box**
- 1 box, 5ea of 10 lb plates = **50 lbs per CWP10(5) box**
- 2 boxes, 5ea of 15 lb plates = **75 lbs per CWP15(5) box**

**NOTE:** Confirm 15 lb weight plates are the lower half of the stack.

Part #	Assembly Parts List	QTY
DFT-021	Weight Plate, 10lbs (4.5kg), Standard 200 lb Weight Stack 19 each Per Side	19
DFT-21B-OPT	OPTION - Weight Plate, 15 lbs (6.8kg), Upgraded 250 lb Weight Stack w/ 18 each #21 Plates	10
DFT-024-ASM	Top Plate- Assembly	1

**STEP 5a: Left Side Main Frame, Reinstall the Hardware & Top Guide Rod Holder**

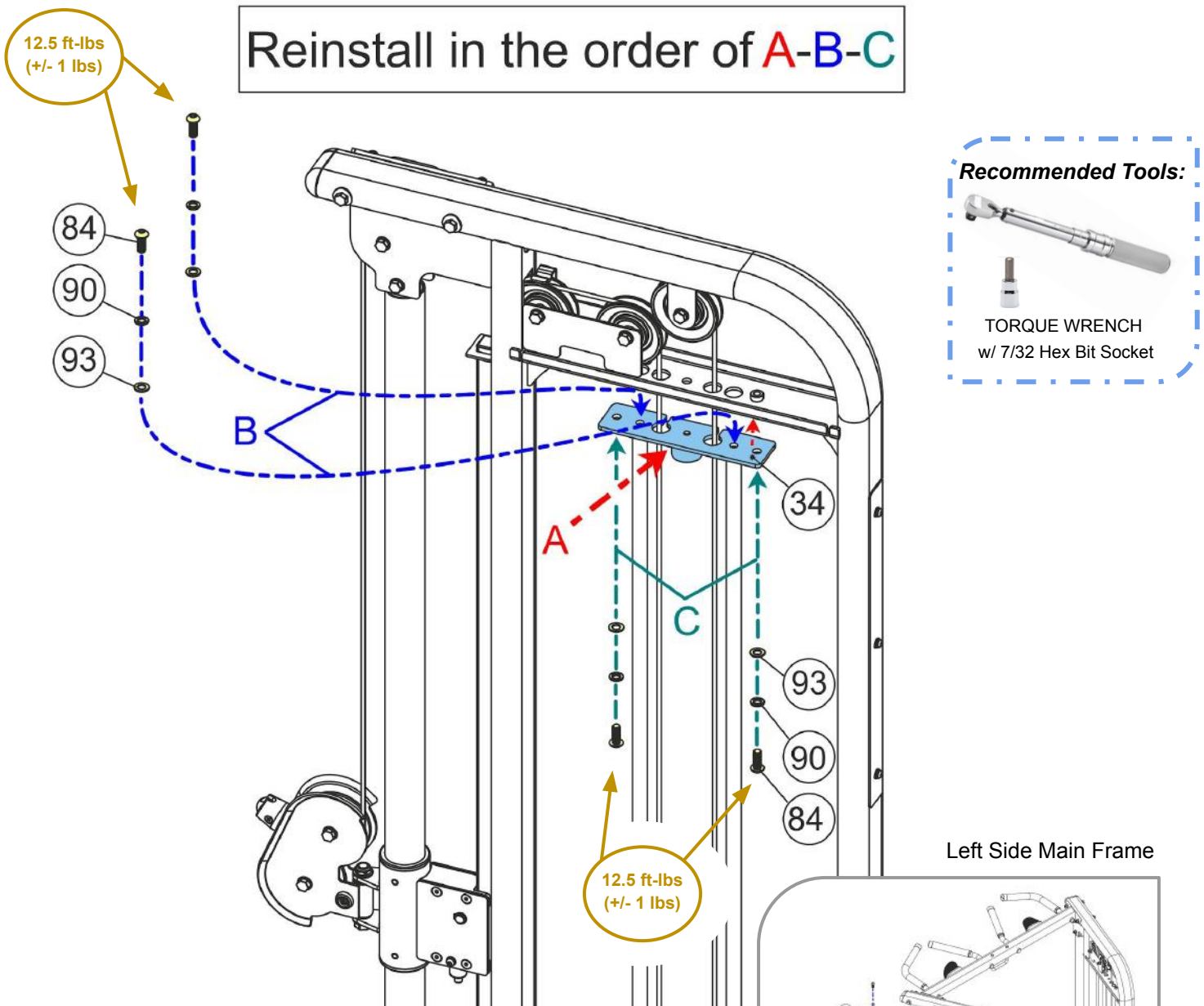

Part #	Pre-Installed Part & Hardware List	QTY
DFT-034	Top Guide Rod Holder Plate	1
DFT-084	Screw, Hex Recessed Flat Head, 3/8" x 1" L	4
DFT-090	Washer, Spring, 3/8"	4
DFT-093	Washer, Flat, 3/8"	4

**STEP 5b: ONLY Tighten STEP 5 Hardware to the Recommended Torque Specs at this time.**

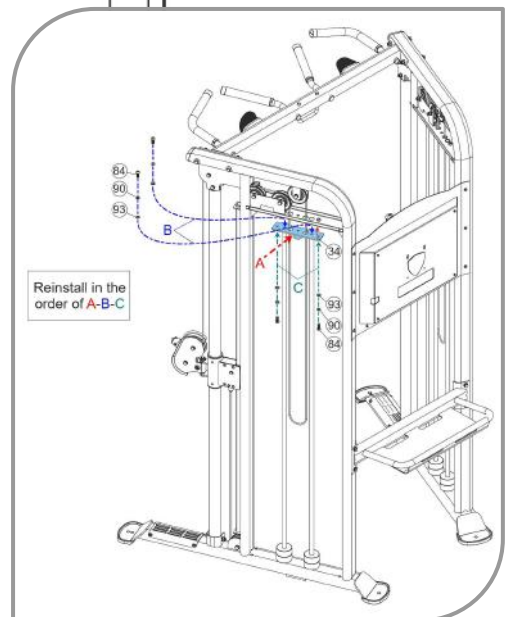



**STEP 6a: Left Side Main Frame, Install Single Block, Pulley, Selector Pin & Single Handle**

Part #	Assembly Parts List	QTY
DFT-013	Pulley Block, Single, w/ Threaded Shaft 1/2" OD	1
DFT-025	Selector Pin w/ Lanyard, Aluminum - BLUE	1
DFT-030	Snap Hook	1
DFT-039	Pulley, Nylon, 90mm (3-1/2") x ̢26mm ID	1
DFT-069	Accessory, Single Handle	1

Part #	Assembly Hardware	QTY
DFT-072	Bolt, Hex Head, 3/8" x 2" L	1
DFT-089	Washer, Spring, 1/2"	1
DFT-093	Washer, Flat, 3/8"	2
DFT-096	Nut, Nylon Lock, 3/8"	1
DFT-098	Nut, Hex, 1/2"	1

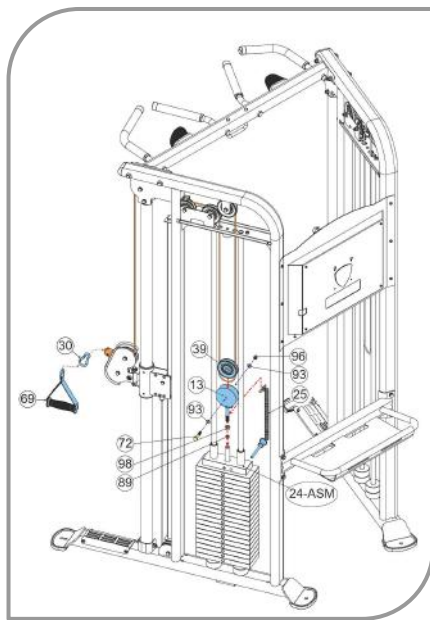

Left Side Main Frame

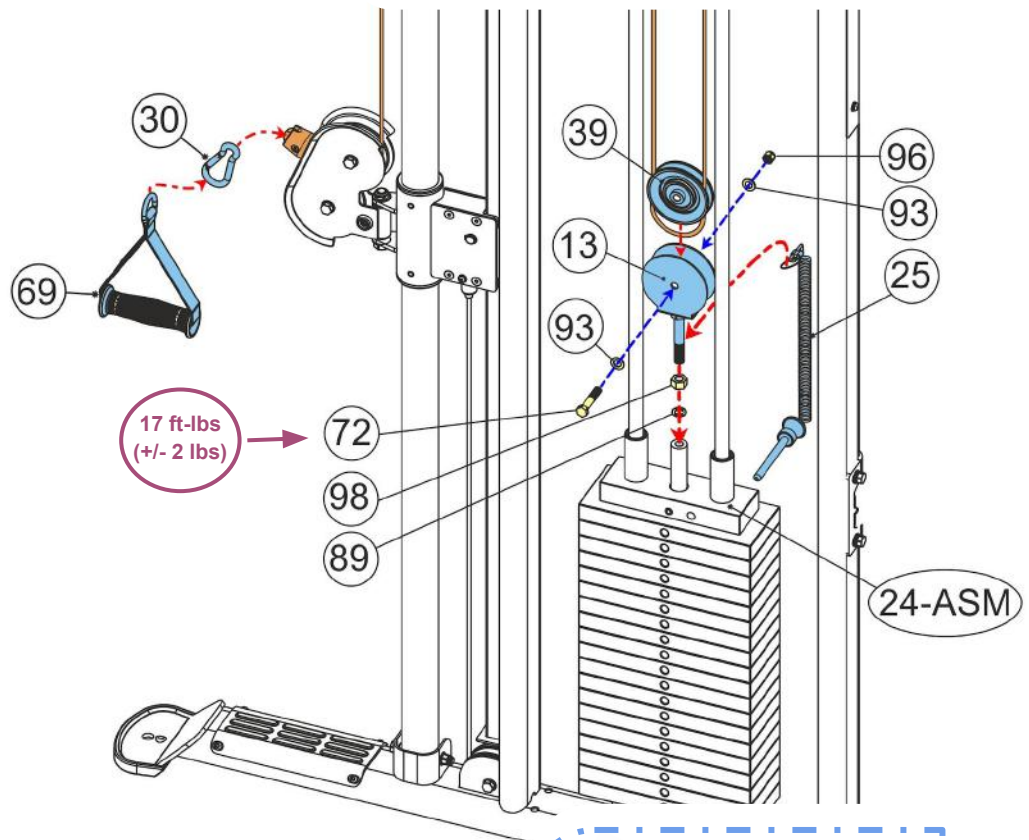

**Recommended Tools:**



TORQUE WRENCH w/ 9/16 SOCKET, 9/16 WRENCH & ADJUSTABLE WRENCH

**STEP 6b: ONLY Tighten STEP 6 Hardware to the Recommended Torque Specs at this time.**

**STEP 6c: Adjust Cable Tension from the Single Pulley Block**

**Good Rule of Thumb:** Cable above weight stack should have less than 1/2 inch of play in the cable.

**NOTE:** Check Selector Rod Pin freely slides into each weight plate front hole with the Top Plate resting on 1st Weight Plate.

Once adjusted correctly, tighten the jam nut.

**BODYCRAFT**

[Watch Assembly Video](#)

DFT STEP 6 & 10  
Adjusting the Cables





**STEP 7: Right Side Main Frame, Removal of Pre-Installed Hardware & Top Guide Rod Holder**

Remove in the order of **A-B-C**

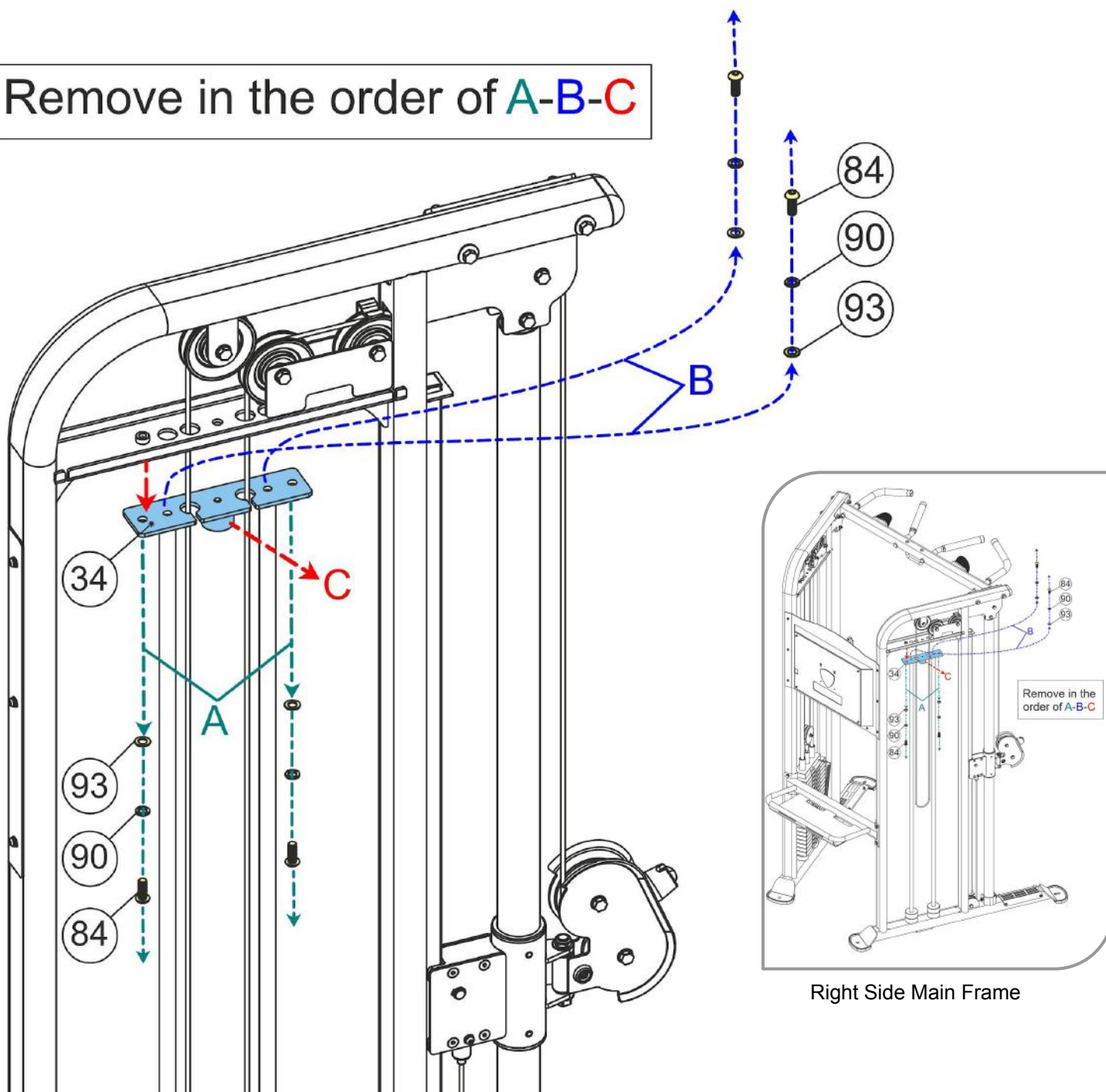

Part #	Pre-Installed Part & Hardware List	QTY
DFT-034	Top Guide Rod Holder Plate	1
DFT-084	Screw, Hex Recessed Flat Head, 3/8" x 1" L	4
DFT-090	Washer, Spring, 3/8"	4
DFT-093	Washer, Flat, 3/8"	4

**Recommended Tool:**

(100)

7/32 ALLEN (HEX)  
WRENCH

**STEP 8: Right Side Main Frame, Lube Guide Rods, Install Weight Plates & Top Plate-ASM**

**NOTE:** Lightly lubing the Guide Rods is a great practice to do at this STEP, but also during scheduled times for preventive maintenance measure.

- Doing this before the weight stack goes on and blocks the potential "dry" part of the Guide Rods, ensures they are lubed.
- Ensures that the Weight Plates internal bushing get a "break-in" lube for a quiet & longer life operation.
- Add protection to the Guide Rods (6) from future potential surface rust in the higher humidity environments.



**Standard 200 lb stack use the following:**

- 1 box, 4ea of 10 lb plates = 40 lbs per CWP10(4) box
- 3 box, 5ea of 10 lb plates = 50 lbs per CWP10(5) box

**Upgraded to 250 lb stack use the following:**

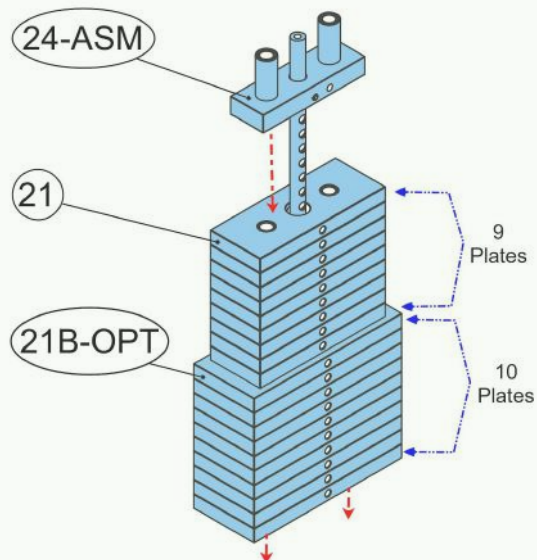

- 1 box, 4ea of 10 lb plates = 40 lbs per CWP10(4) box
- 1 box, 5ea of 10 lb plates = 50 lbs per CWP10(5) box
- 2 boxes, 5ea of 15 lb plates = 75 lbs per CWP15(5) box

**NOTE: Confirm 15 lb weight plates are the lower half of the stack.**

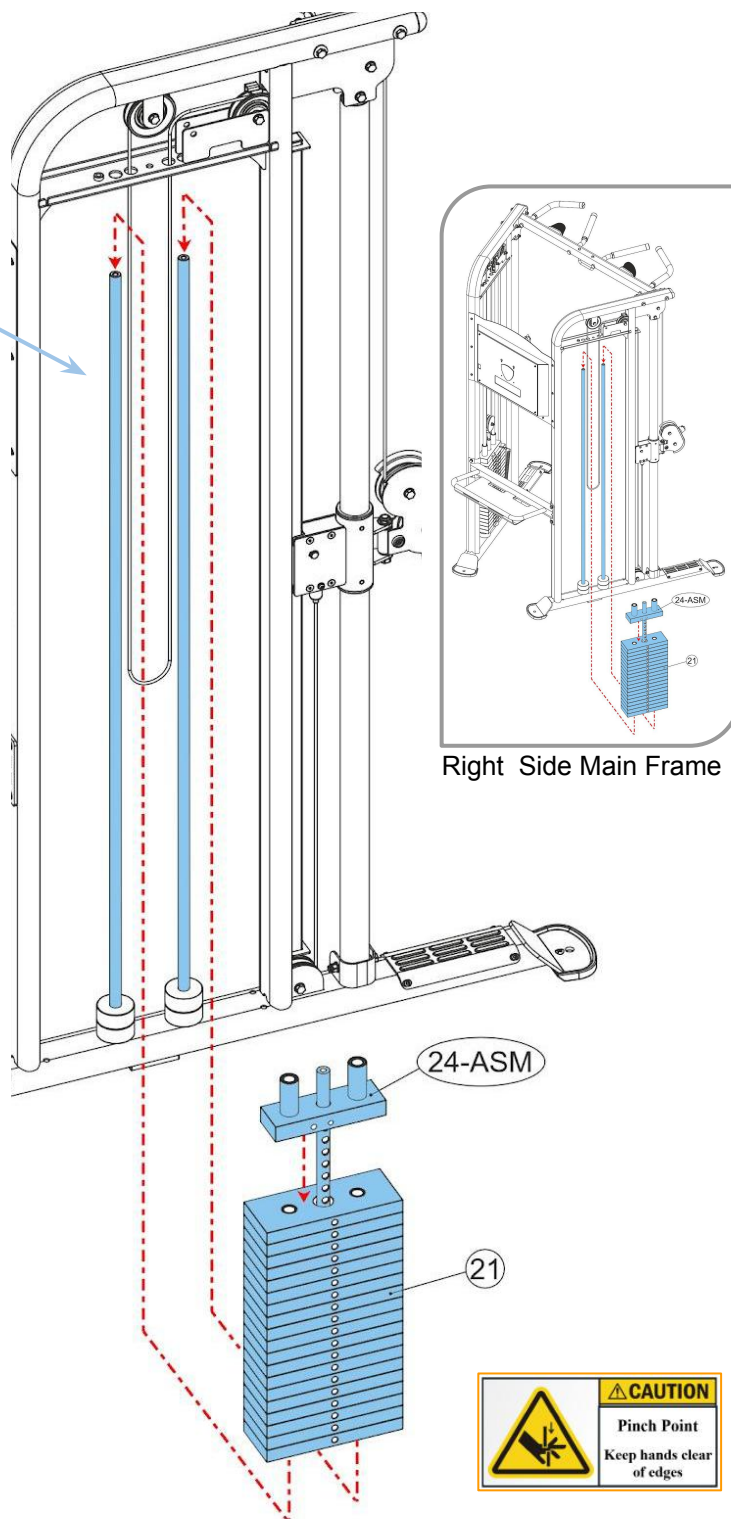

Part #	Assembly Parts List	QTY
DFT-021	Weight Plate, 10lbs (4.5kg), Standard 200 lb Weight Stack 19 each Per Side	19
DFT-21B-OPT	OPTION - Weight Plate, 15 lbs (6.8kg), Upgraded 250 lb Weight Stack w/ 18 each #21 Plates	10
DFT-024-ASM	Top Plate- Assembly	1

**STEP 9a: Right Side Main Frame, Reinstall the Hardware & Top Guide Rod Holder**

Reinstall in the order of **A-B-C**

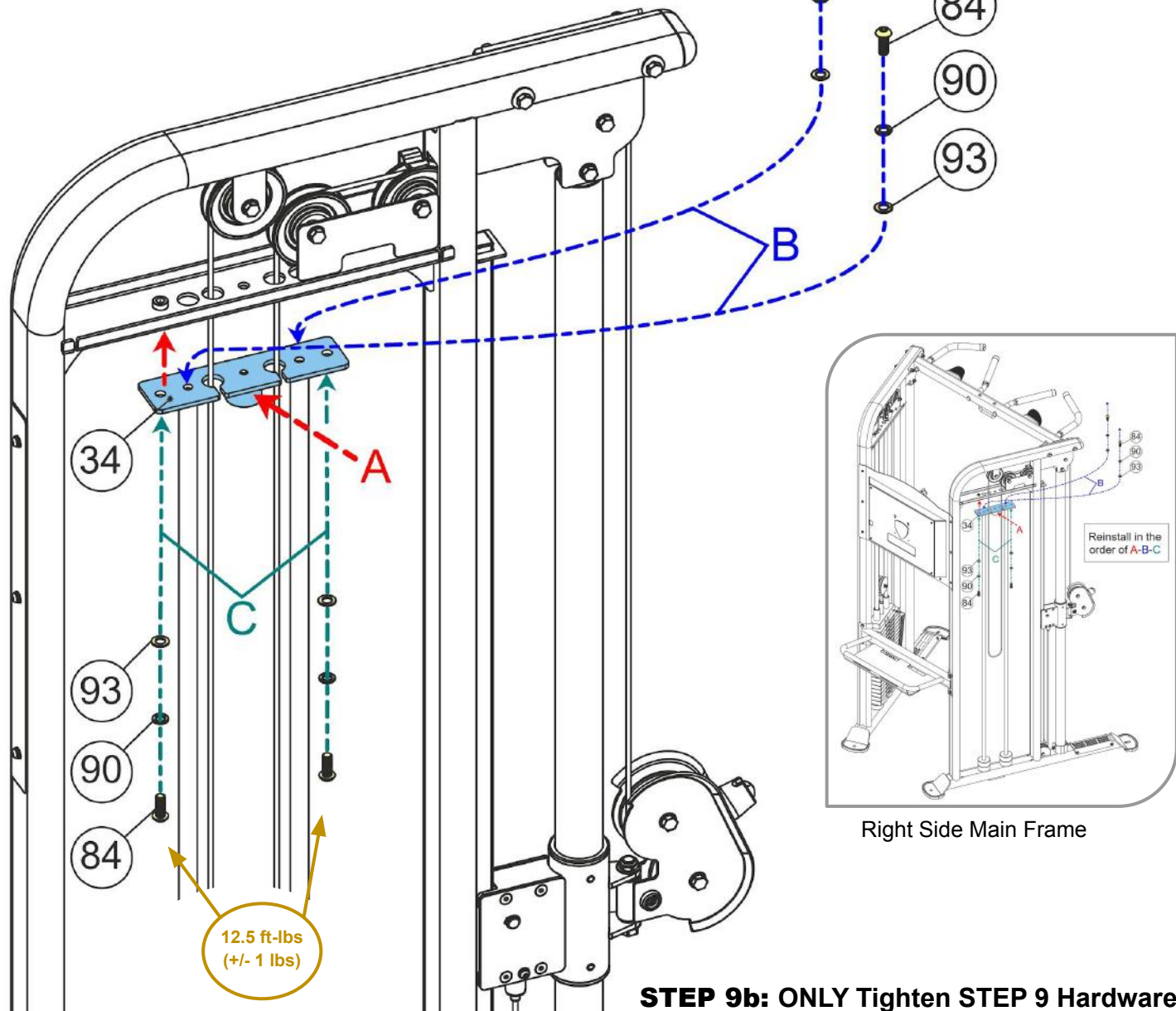

Right Side Main Frame

**STEP 9b: ONLY Tighten STEP 9 Hardware to the Recommended Torque Specs at this time.**

Part #	Pre-Installed Part & Hardware List	QTY
DFT-034	Top Guide Rod Holder Plate	1
DFT-084	Screw, Hex Recessed Flat Head, 3/8" x 1" L	4
DFT-090	Washer, Spring, 3/8"	4
DFT-093	Washer, Flat, 3/8"	4

**Recommended Tools:**



TORQUE WRENCH  
w/ 7/32 Hex Bit Socket



**STEP 10a: Right Side Main Frame, Install Single Block, Pulley, Selector Pin & Single Handle**

Part #	Assembly Parts List	QTY
DFT-013	Pulley Block, Single, w/ Threaded Shaft 1/2" OD	1
DFT-025	Selector Pin w/ Lanyard, Aluminum - BLUE	1
DFT-030	Snap Hook	1
DFT-039	Pulley, Nylon, 90mm (3-1/2") x ̢26mm ID	1
DFT-069	Accessory, Single Handle	1

Part #	Assembly Hardware	QTY
DFT-072	Bolt, Hex Head, 3/8" x 2" L	1
DFT-089	Washer, Spring, 1/2"	1
DFT-093	Washer, Flat, 3/8"	2
DFT-096	Nut, Nylon Lock, 3/8"	1
DFT-098	Nut, Hex, 1/2"	1

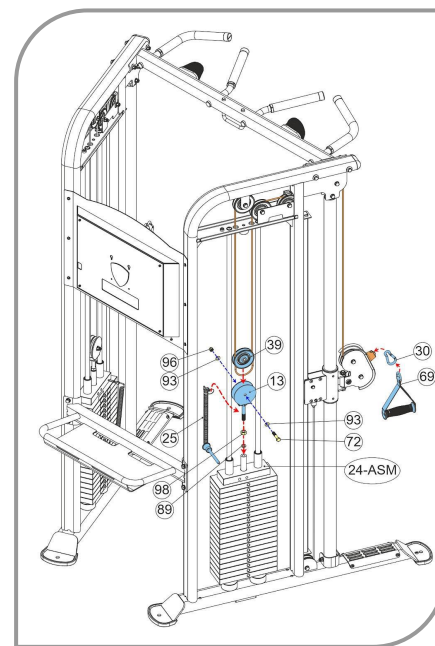
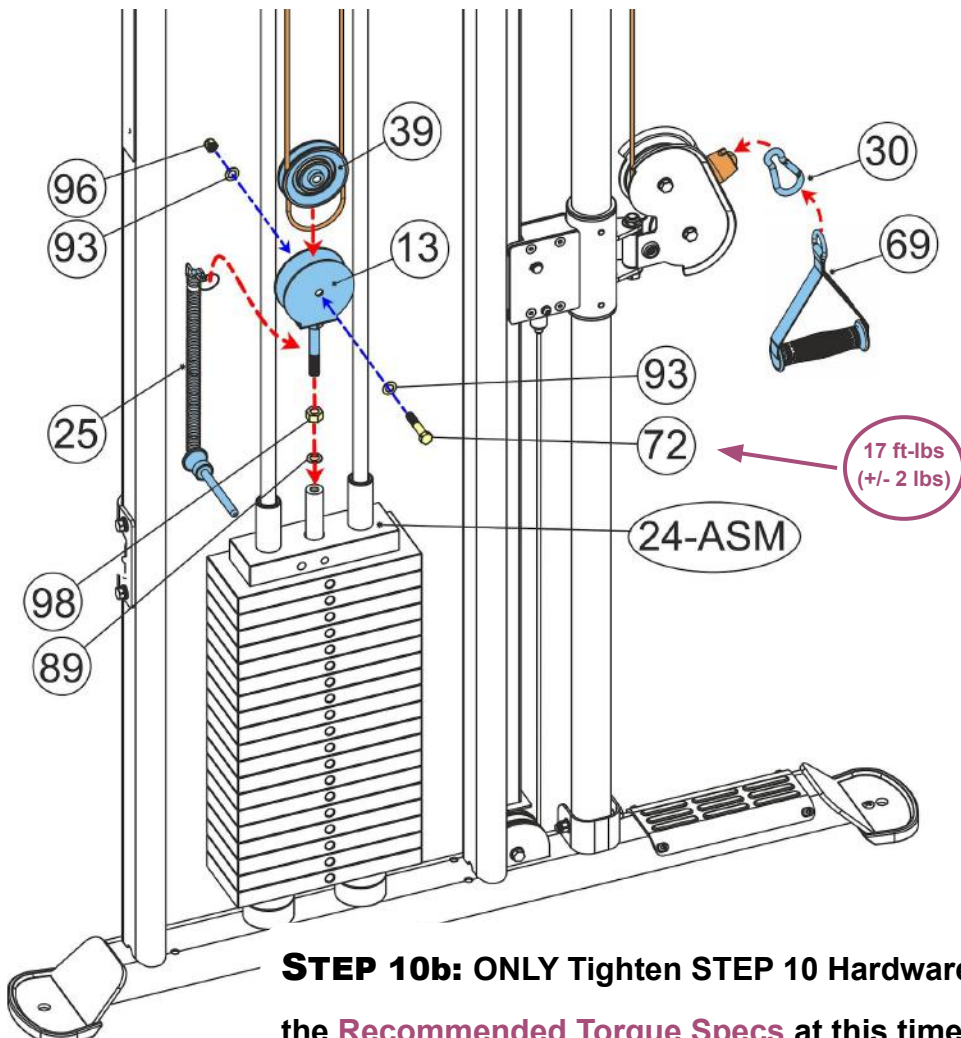

Right Side Main Frame

**STEP 10b: ONLY Tighten STEP 10 Hardware to the Recommended Torque Specs at this time.**

**Recommended Tools:**



TORQUE WRENCH w/ 9/16 SOCKET, 9/16 WRENCH & ADJUSTABLE WRENCH

**STEP 10c: Adjust Cable Tension from the Single Pulley Block**

**Good Rule of Thumb:** Cable above weight stack should have less than 1/2 inch of play in the cable.

**NOTE:** Check Selector Rod Pin freely slides into each weight plate front hole with the Top Plate resting on 1st Weight Plate.

Once adjusted correctly, tighten the jam nut.



[Watch Assembly Video](#)

DFT STEP 6 & 10  
Adjusting the Cables





**STEP 11: "Torque Time" on ALL Frame Nuts & Bolts from STEP 1a, 1b & 2**

**NOTE:** These recommended torque specs should be followed for correct assembly and safe operation of this machine.



Example of being overtightened not using the recommended torque specs.

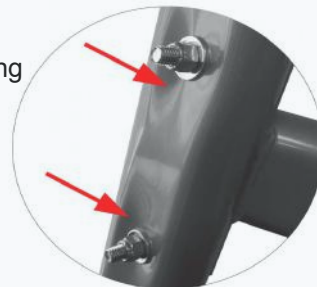

Tighten to torque specs to ensure the bolts and nuts do the following:

- Securely hold the frame and keep moving parts from coming loose during operation.
- Keep from crushing the frame.
- Avoid stripping the threads on either the bolts or nuts.
- Allow moving parts to adjust freely per the designed intent.



<https://www.wikihow.com/Use-a-Torque-Wrench#Video>

**Recommended Tools:**



TORQUE WRENCH w/ 9/16 SOCKET, 9/16 WRENCH & 4mm HEX BIT SOCKET

Tighten the frame **Nuts & Bolts** to the recommended torque specs.

**NOTE:** Start at the bottom then work your way up to the top.

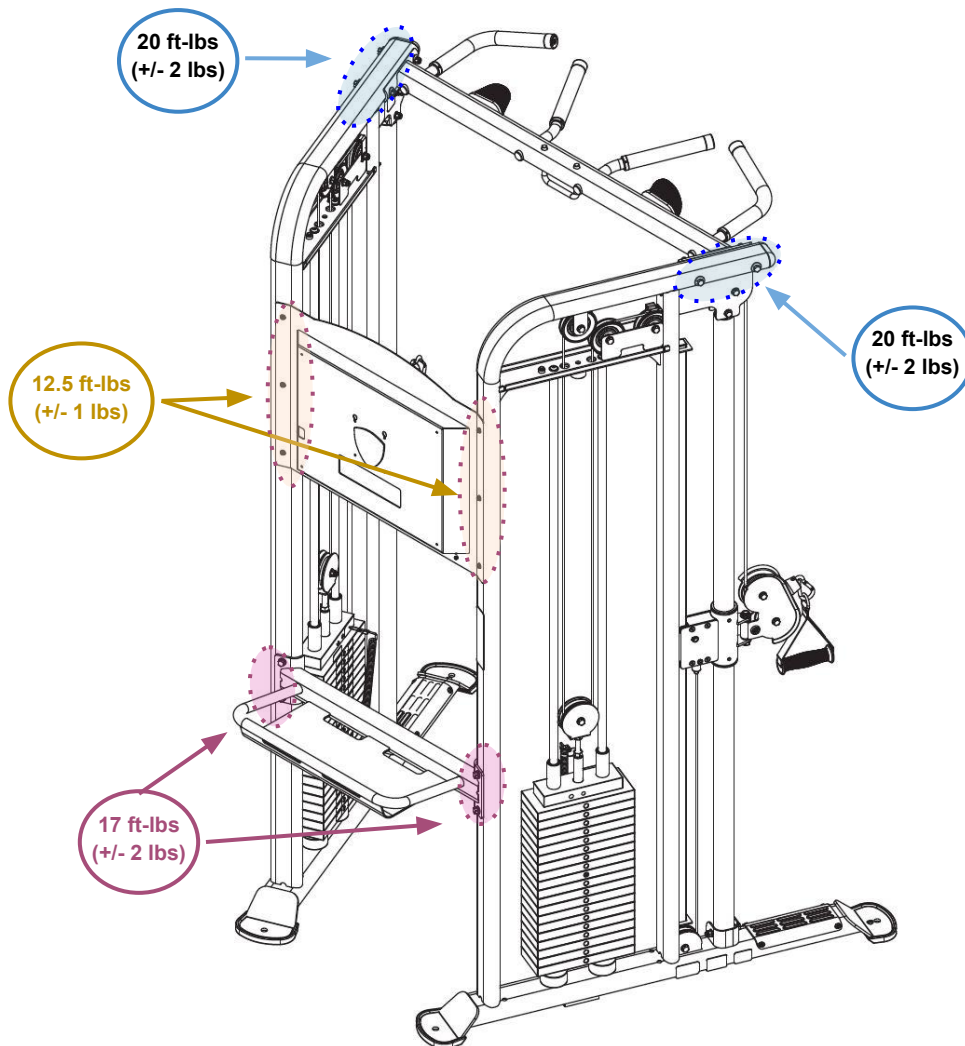

# Product Assembly, Weight Stack Stickers Installation, DFT

## STEP 12a: Clean Weight Stacks

**IMPORTANT:** Before installing the weight stack stickers, it is important to let the weight plates acclimate to room temperature.



MINIMUM 65 DEGREES & LOW HUMIDITY



RUBBING ALCOHOL



CLEAN COTTON CLOTH

Clean Top Plate & Weight Plates front surface with:

- Rubbing Alcohol
- Clean Cotton Cloth.

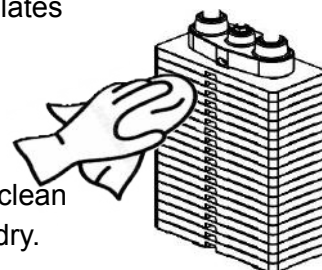

Then wipe dry with another clean cloth or allow to completely air dry.

## STEP 12b: Install Weight Stack Stickers

Standard 200 lb = Sticker Set 1 & 2

Optional 250 lb = Sticker Set 1 & 3

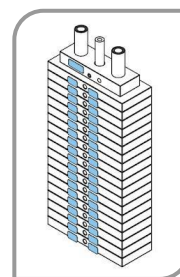
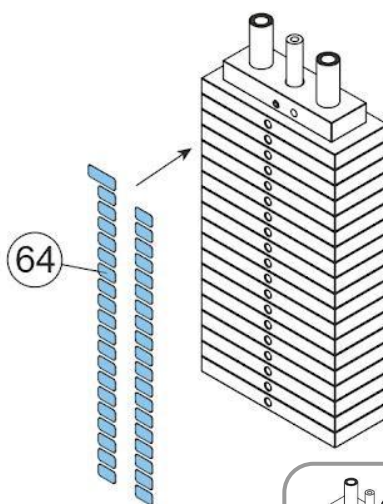
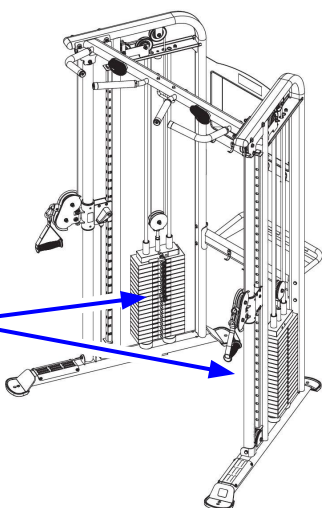

SET 1	SET 2	SET 3
<b>TOP PLATE</b> 10 lbs/4.5 kgs	110 lbs ○ 49.9 kgs	115 lbs ○ 52.1 kgs
20 lbs ○ 9.0 kgs	120 lbs ○ 54.4 kgs	130 lbs ○ 58.9 kgs
30 lbs ○ 13.6 kgs	130 lbs ○ 59.0 kgs	145 lbs ○ 65.7 kgs
40 lbs ○ 18.1 kgs	140 lbs ○ 63.5 kgs	160 lbs ○ 72.5 kgs
50 lbs ○ 22.7 kgs	150 lbs ○ 68.0 kgs	175 lbs ○ 79.3 kgs
60 lbs ○ 27.2 kgs	160 lbs ○ 72.6 kgs	190 lbs ○ 86.1 kgs
70 lbs ○ 31.8 kgs	170 lbs ○ 77.1 kgs	205 lbs ○ 92.9 kgs
80 lbs ○ 36.3 kgs	180 lbs ○ 81.6 kgs	220 lbs ○ 99.8 kgs
90 lbs ○ 40.8 kgs	190 lbs ○ 86.2 kgs	235 lbs ○ 106.6 kgs
100 lbs ○ 45.4 kgs	200 lbs ○ 90.7 kgs	250 lbs ○ 113.4 kgs

STICKER SET 1 IS USED FOR BOTH STANDARD 200 LB AND UPGRADED 250 LB WEIGHT STACKS (PLATES 1-10, INCLUDES TOP PLATE)

STICKER SET 2 IS USED FOR ONLY THE STANDARD 200 LB WEIGHT STACK (PLATES 11-20, 10LB PLATES)

STICKER SET 3 IS USED FOR ONLY THE UPGRADED 250 LB WEIGHT STACK (PLATES 11-20, 15LB PLATES)

Once the correct sticker is carefully aligned to each weight plate, press each number sticker gently onto the weight plate. Only rub each sticker and not the surrounding area.

**NOTE:** Minimum cure time of 24 hrs.

Do Not "TEST" the decals by pulling on them.

**STEP 13: Install Weight Stack Shrouds**

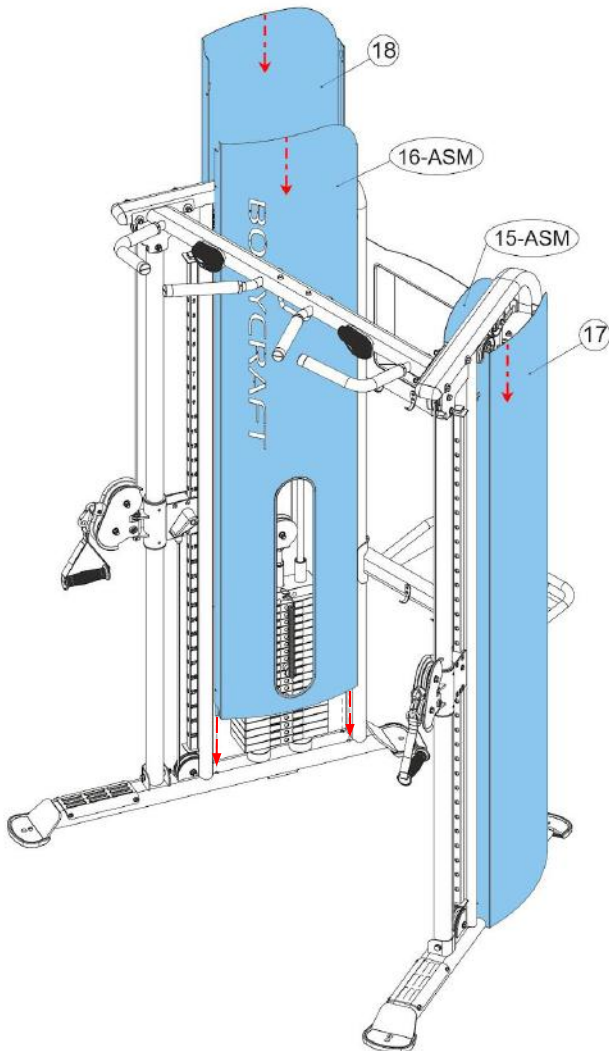
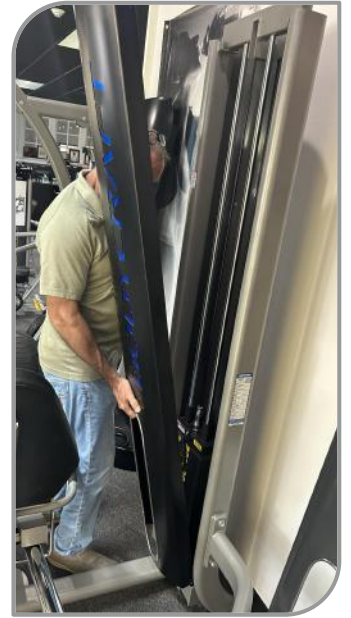
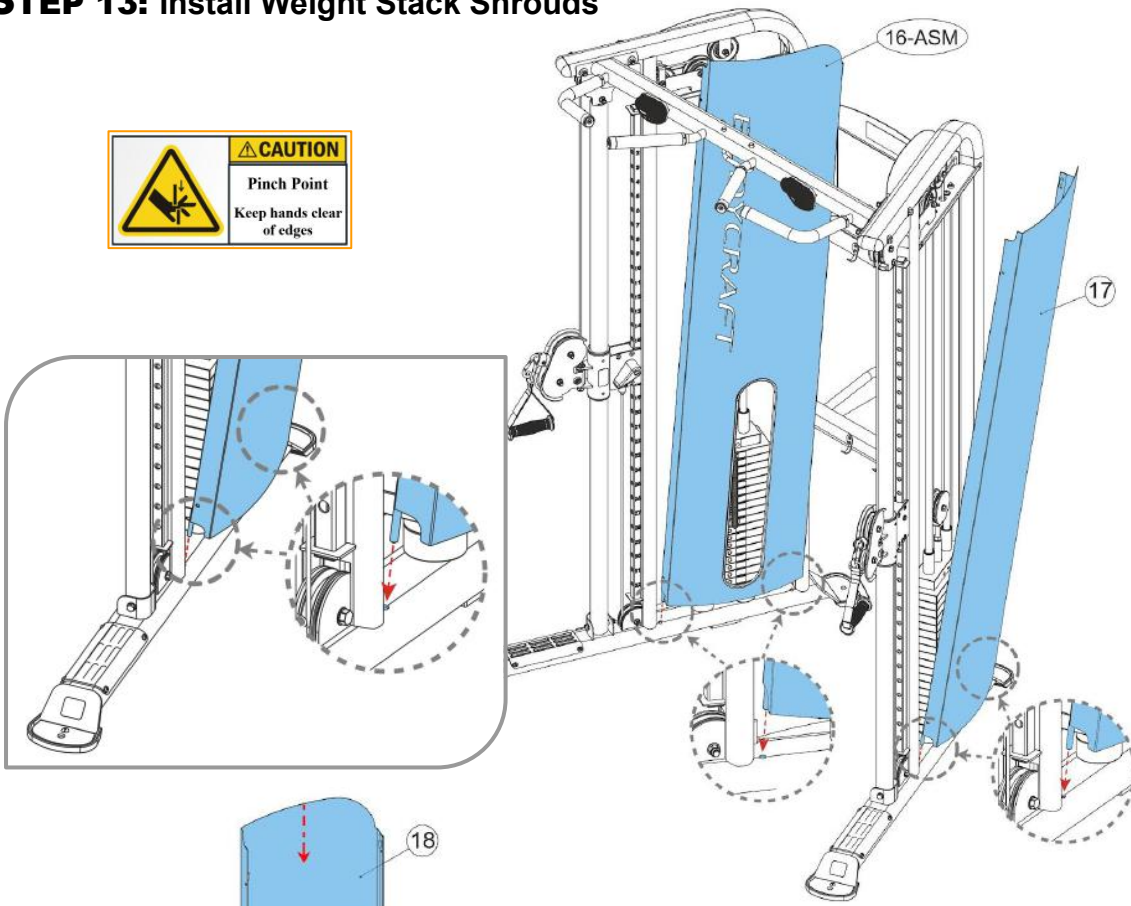

Part #	Assembly Parts List	QTY
DFT-015-ASM	Weight Stack Shroud Cover, Front, Left - Assembly	1
DFT-016-ASM	Weight Stack Shroud Cover, Front, Right - Assembly	1
DFT-017	Weight Stack Shroud Cover, Rear, Left	1
DFT-018	Weight Stack Shroud Cover, Rear, Right	1

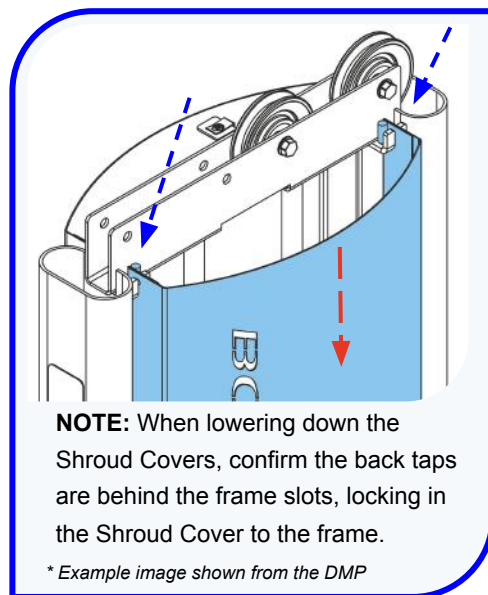



**STEP 14: Install Accessories**

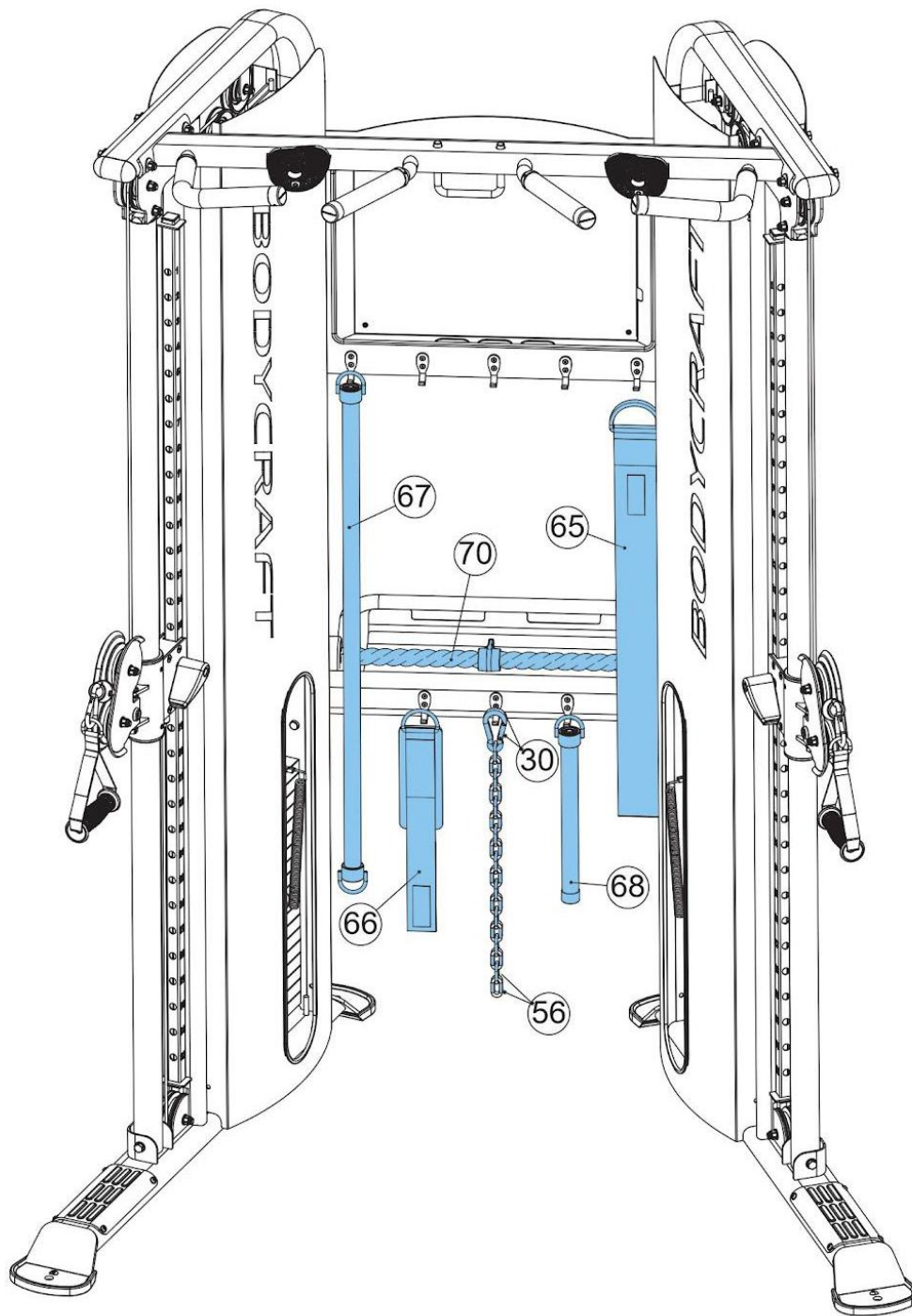

Part #	Assembly Parts List	QTY
DFT-030	Snap Hook	2
DFT-056	Accessory, Chain, 19.7" L	2
DFT-065	Accessory, Long Strap, 1,300mm L	1
DFT-066	Accessory, Ankle Cuff (Leg Strap)	1
DFT-067	Accessory, Long Bar, 1,010mm L	1
DFT-068	Accessory, Short Bar, 365mm L	1
DFT-070	Accessory, Nylon Triceps Rope	1





**STEP 15a:** Remove any & all Assembly Stickers, i.e. Part Numbers & Right / Left Circles

- Easy to remove with fingernail or plastic scraper
- If adhesive residue is on frame:
  - Use rubbing alcohol
  - Then mild cleaning solution
  - Finishing with a dry 100% cotton cleaning cloth



**STEP 15b:** Frame Clean Up

- Wipe down frame with mild cleaning solution
- Dry frame with 100% cotton cleaning cloth
- Good practice to do before first use and yearly:
  - Lightly apply an automotive grade cleaner wax
  - Then follow up by wiping excesses off with 100% cotton cleaning cloth



MILD CLEANING SOLUTION



100% COTTON CLEANING CLOTHS

- DO NOT USE ABRASIVE CLEANING SCRUBBING PADS
- DO NOT USE AMMONIA OR CITRIC CLEANERS
- DO NOT USE ANY FORM OF PAINT THINNERS

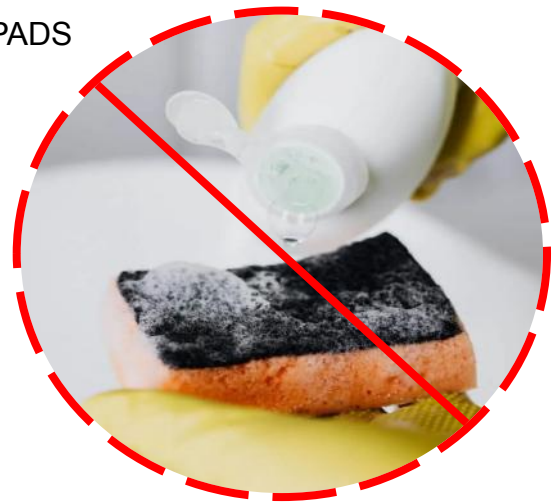

**TIP ON FRAME ONLY:** For extra protection from fingerprints, sweat stains or just plain dirt, apply an automotive grade cleaner wax if desired. Also makes future cleaning easier.



**(Do Not Use on the Upholstery)**

## Product Assembly, Routine Schedule

<i>ROUTINE SCHEDULE</i>	<i>LIGHT COMMERCIAL</i>	<i>HOME</i>
<b>Clean:</b> Upholstery.	DAILY	1 - 2 WEEKS
<b>Inspect:</b> Cables or Belts and their tension.	DAILY	1 - 2 WEEKS
<b>Inspect:</b> Links, Pull Pins, Snap Locks, Swivels, and Weight Stack Pins.	DAILY	1 - 2 WEEKS
<b>Inspect:</b> Accessory Bars and Handles.	WEEKLY	3 - 6 MONTHS
<b>Inspect:</b> All Label and Weight Stack Stickers.	WEEKLY	3 - 6 MONTHS
<b>Inspect:</b> All Nuts and Bolts, tighten if needed.	WEEKLY	3 - 6 MONTHS
<b>Inspect:</b> Anti-Skid Surface.	WEEKLY	3 - 6 MONTHS
<b>Clean &amp; Lubricate:</b> Guide Rods with 100% Silicone or a Teflon based lubricant with Super Lube (a PTFE grease).	MONTHLY	3 - 6 MONTHS
<b>Lubricate:</b> Seat Sleeves, Bushings, Linear Bearing.	MONTHLY	3 - 6 MONTHS
<b>Clean and Wax:</b> All Glossy Finishes.	6 MONTHS	YEARLY
<b>Repack with Grease:</b> Linear Bearings.	6 MONTHS	YEARLY
<b>Replace:</b> Cables, Belts and Connecting Parts when showing signs of wear.	YEARLY	2 - 4 YEARS

### General Inspection and Cleaning

The Frame should be wiped down with a damp cloth and dried on a daily basis. The powder coat finish should be polished with a good car wax on a yearly basis. For Vinyl Upholstery use Lanolin hand cleaner to dissolve sweat and lubricate the vinyl, maintaining its natural flexibility. DO NOT use cleaners such as Lysol or Windex as they will dry out and crack the vinyl. Sweat is corrosive and when left on the frame and components will eventually cause corrosion or rust. When performing these cleaning sessions, it is the perfect time to inspect the equipment and note any problems for the maintenance personnel to correct.

1. Check equipment to ensure it is operating properly.
2. Check the cables for loose fittings or frayed cable(s) and to ensure seating is proper on the pulleys and cams (if equipped).
3. Make sure that the proper weight stack selector pin is with each machine and that the pin functions properly.
4. If something appears loose, be sure to have it tightened immediately.
5. If a piece of equipment appears damaged or not operating properly, place the piece out-of-service immediately.

### Cable Inspection

It is important to inspect the cables frequently, replace any worn out cables to prevent a sudden failure that can result in an injury. Cables are moving parts, meaning cable-wear will occur regardless of the type or size used.

1. Inspect cable ends and perform any cable tension adjustments, loosen the jam nut and thread the cable bolt in or out to give cable the proper tension. Re-tightened all jam nuts when adjustment is complete and make sure the cable bolt is threaded 1/3 into the socket of the selector stem in the top plate.
2. Check the cables as they pass over all pulley wheels. Visually inspect the cables and pulleys. A cable that is wearing will exhibit a ballooned surface that passes over the pulleys. This is an early warning sign to replace the cable(s).



### Lubrication

Bearing and linear bearing systems have advanced over the years, but they must be maintained on a regular basis if you expect them to last and perform efficiently. BODYCRAFT uses only the highest quality bearings and linear motion components that are virtually trouble-free but they require the regular preventive maintenance to ensure long-lasting performance.

- 1. Bronze bushings:** Recommend on a yearly basis to spray a Teflon-base lubricant (silicone-free) directly onto the shaft as it passes through these bushings. Spray a small amount onto the shaft and rotate it through its complete movement and wipe off any excess.
- 2. Weight stack guide rods:** Use Silicone Spray lubricant and this time spray onto a rag and wipe the guide rods down with this rag on a weekly basis. DO NOT use WD-40 or other lubricants as they attract dirt and will create a mess between the weight plates and bushings.
- 3. Sealed bearings pivot points:** As the name implies, they are protected from the outside environment and require no lubrication. During the machine wipe down, wipe the external bearing surfaces with the damp rag and dry to prevent the build up of dust and sweat.
- 4. Linear bearing systems (if equipped):** These are precision, high load components that require regular maintenance. Dirt and corrosion are the major culprits in linear bearing failure. The hardened shafts must be wiped down monthly and lubricated with a light layer of Teflon grease. We recommend a Teflon-based (silicone-free) gel/grease for this purpose. Lack of care and maintenance will result in corrosion of the linear shaft causing the bearings to become clogged and jammed.

If you perform the maintenance procedures, you will increase the life of the machine and ultimately lower your maintenance costs with fewer replaced components and downtime.



BODYCRAFT  
7699 GREEN MEADOWS DR.  
LEWIS CENTER, OHIO 43035



800.990.5556  
SERVICE@BODYCRAFT.COM  
WWW.BODYCRAFT.COM



## Strength Cable Wear Indicators

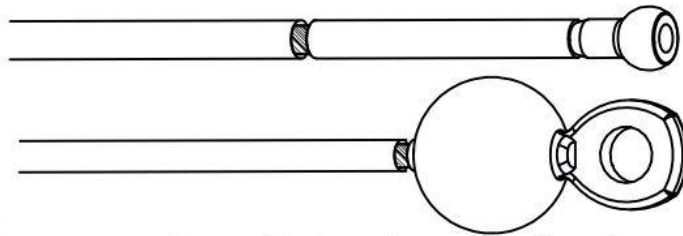
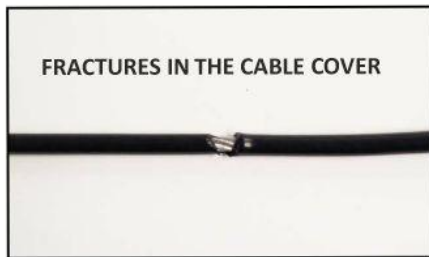

Casing can crack or fracture under strains during use. Any crack in the casing merits cable replacement even if no wire rope is exposed.

**STOP USING THE MACHINE: This cable needs to be replaced as soon as possible.**

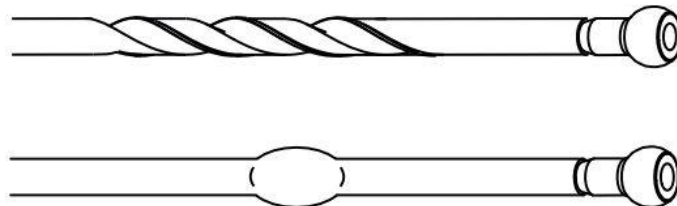

Inspect casing to ensure wire rope is not tearing, twisting, or binding within and coil causing bulge to appear. Cable should retain same outside diameter throughout.

**STOP USING THE MACHINE: This cable needs to be replaced as soon as possible.**

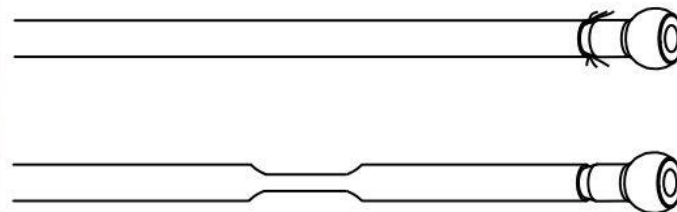

Any exposed wire rope protruding through the casing or at either end, has lost its structural integrity. Section of cable is compressed and will not retain its shape (outside diameter).

**STOP USING THE MACHINE: This cable needs to be replaced immediately.**

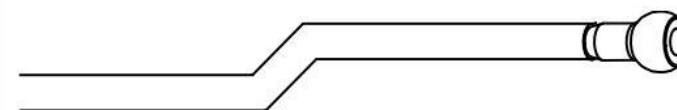

Cable has a kink and prohibits cable from lying straight. Wire rope may be unraveling beneath the casing, causing a compromise of its structural integrity.

**STOP USING THE MACHINE: This cable needs to be replaced immediately.**

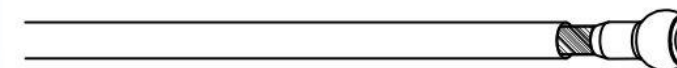

Watch for component end of cable to pull away from cable assembly and look for exposed wire rope.

**STOP USING THE MACHINE: This cable needs to be replaced immediately.**

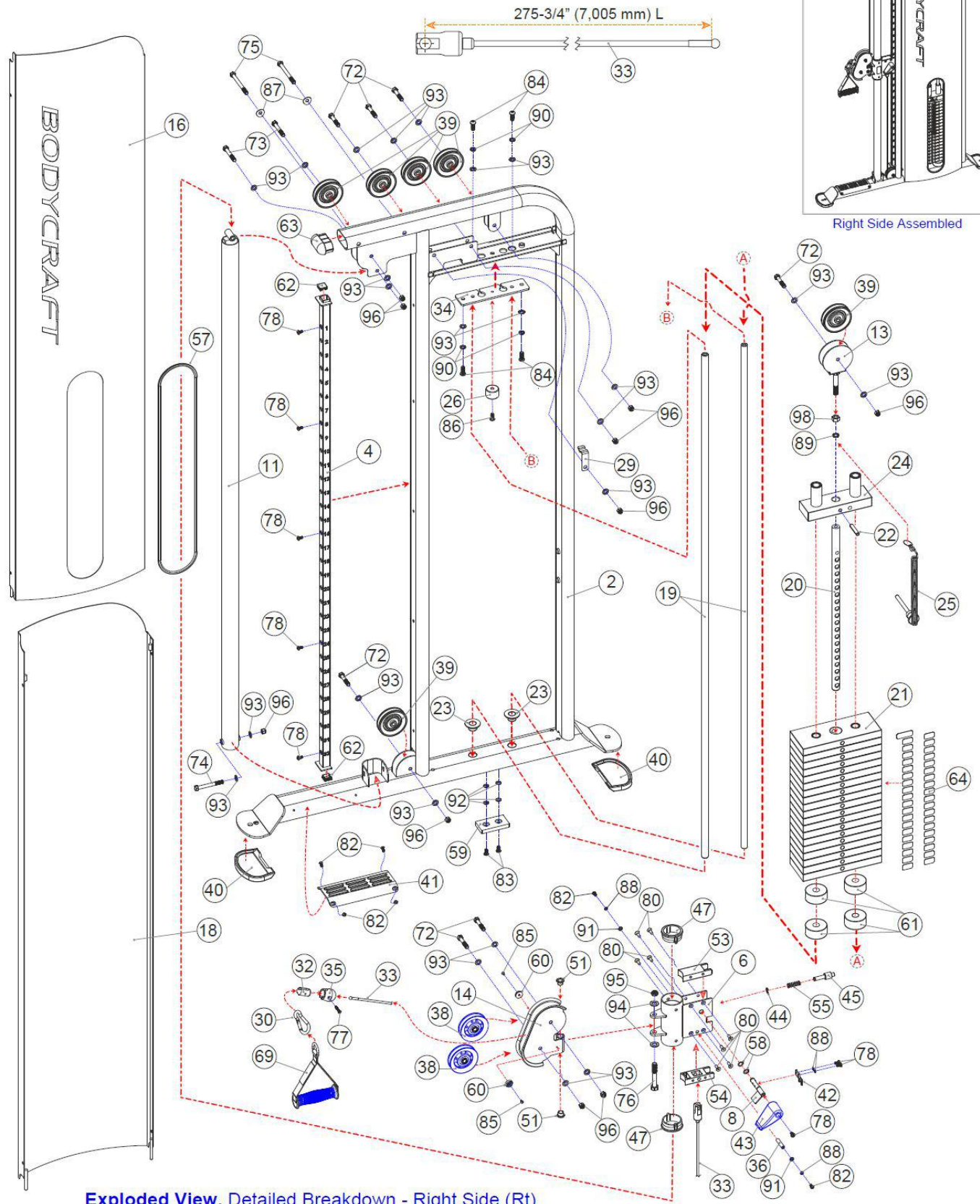
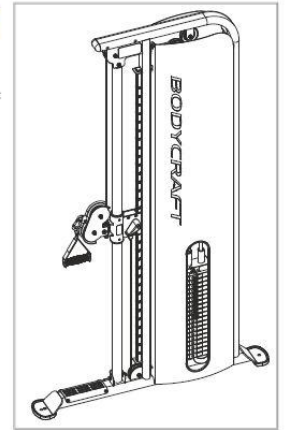



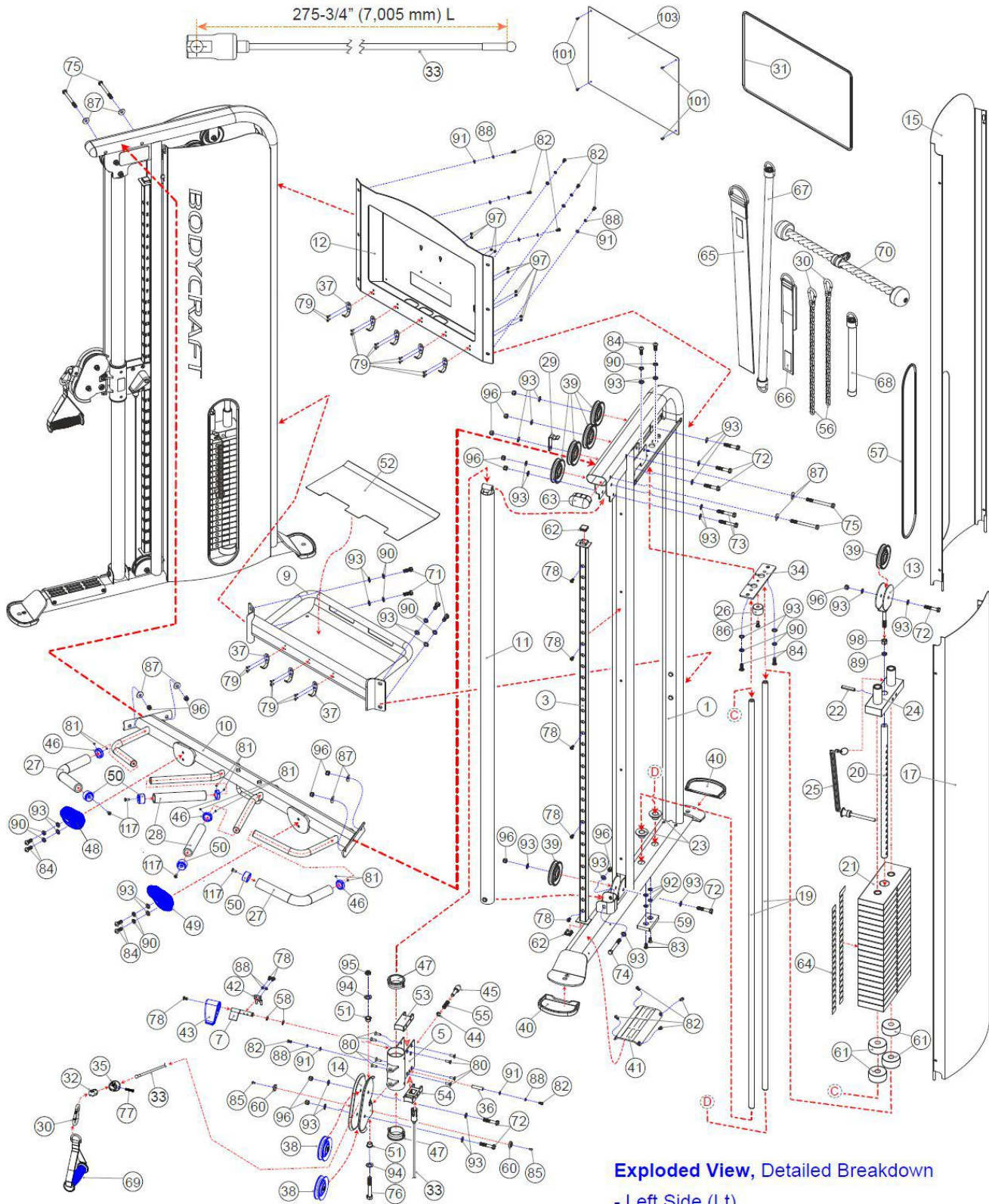

**Exploded View, Detailed Breakdown**

- Left Side (Lt)
- Center Sections
- Accessories

**NOTE:** Parts are not to scale

# Detailed Parts, Cable Routing, DFT

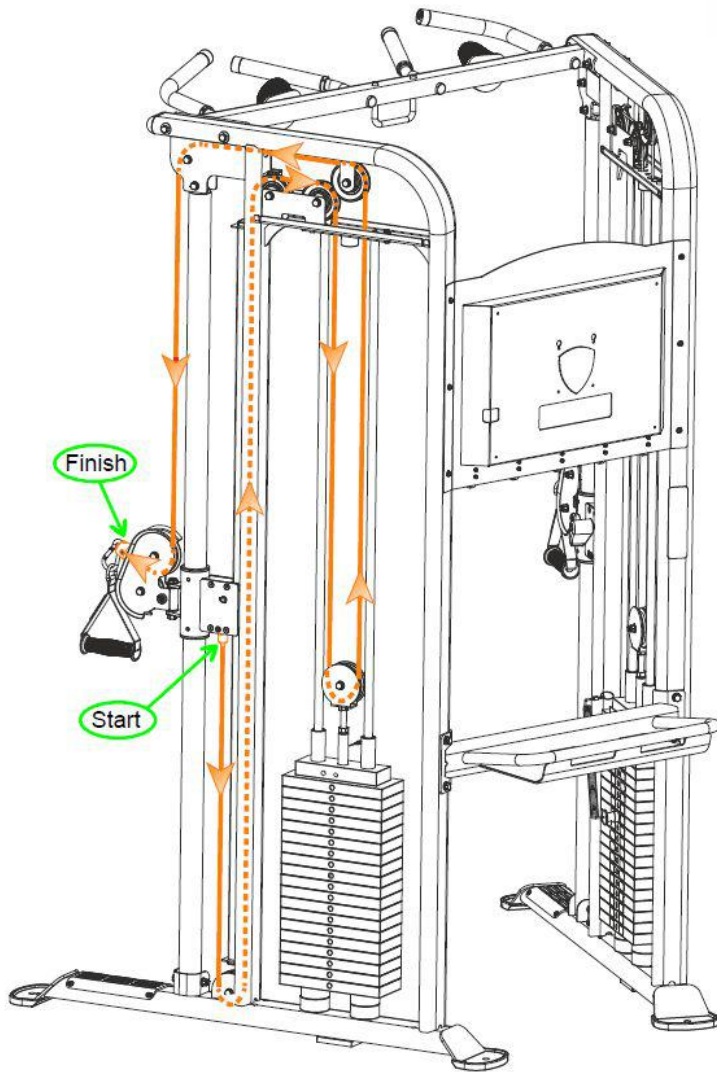
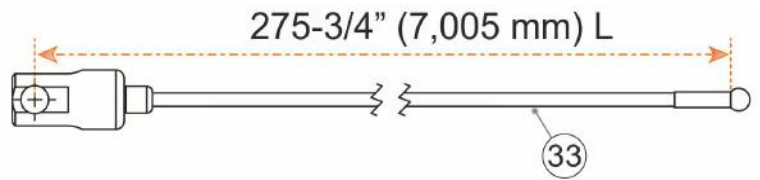

Left Side (Lt)

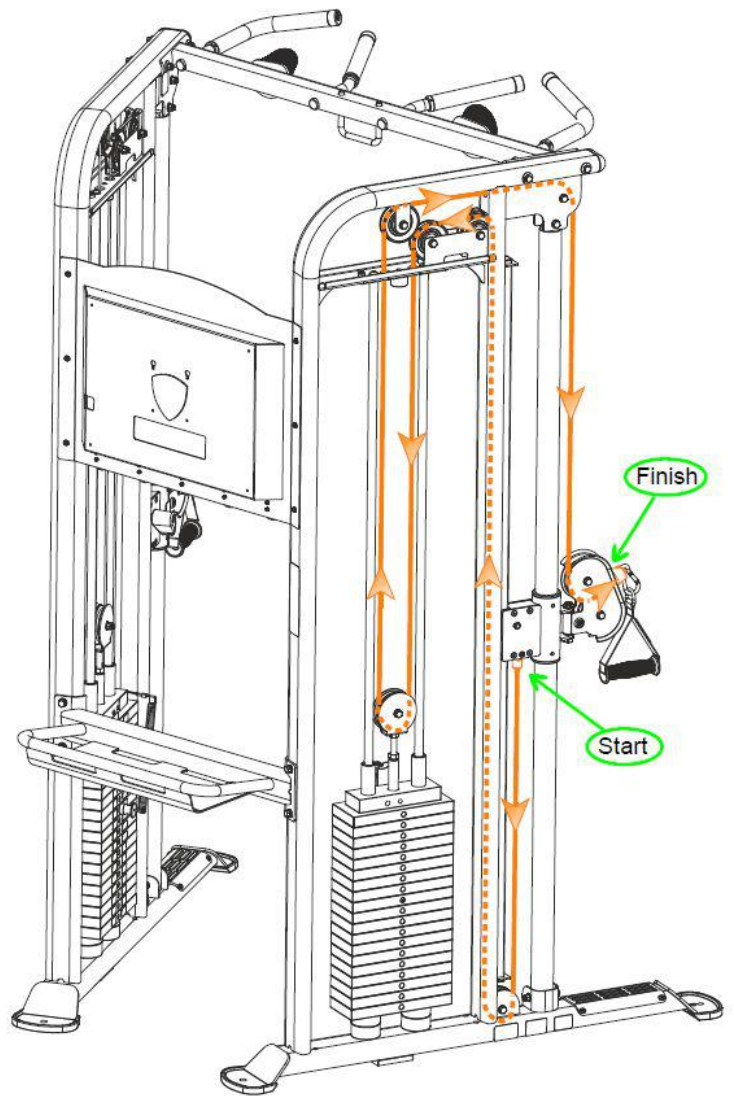

Right Side (Rt)

## View Keys

- Red dotted (large):** Structural parts assembled direction.
- Red dotted (med):** Sub-parts assembled direction.
- Blue dotted lines (small):** Hardware assembled direction.
- Orange (med):** Cables are normally black, but easier to see in color.

**NOTE:** Parts are not to scale



# Detailed Parts List, DFT

Part #	Detailed Parts List	QTY
DFT-001	Frame, Main, Left	1
DFT-002	Frame, Main, Right	1
DFT-003	Height Adjustment Track, Left, for Pulley Height Adjuster w/ Bar Catch	1
DFT-004	Height Adjustment Track, Right, for Pulley Height Adjuster w/ Bar Catch	1
DFT-005	Pulley Height Adjuster, w/ Bar Catch, Left	1
DFT-006	Pulley Height Adjuster, w/ Bar Catch, Right	1
DFT-007	Lock Adjusting Lever, Left	1
DFT-008	Lock Adjusting Lever, Right	1
DFT-009	Frame, Connecting, Bottom w/ Accessory Tray	1
DFT-010	Chinbar w/ Multi-Grip Bars & Rock Climbing Grips	1
DFT-011	Guide Tube, for Pulley Height Adjuster w/ Bar Catch	2
DFT-012	Frame, Connecting, Top w/ Bookrack & Accessory Holder	1
DFT-013	Pulley Block, Single, w/ Threaded Shaft 1/2" OD	2
DFT-014	Rotating Pulley Holder	2
DFT-015	Weight Stack Shroud Cover, Front, Left	1
DFT-016	Weight Stack Shroud Cover, Front, Right	1
DFT-017	Weight Stack Shroud Cover, Rear, Left	1
DFT-018	Weight Stack Shroud Cover, Rear, Right	1
DFT-019	Guide Rod for Weight Stack, 0.75" OD x 50.3" L, 3/8" Inner Thread on One End	4
DFT-020	Selector Rod, 19 Holes	2
DFT-021	Weight Plate, 10lbs (4.5kg), Standard 200 lb Weight Stack 19ea. per side	38
DFT-21B-OPT	OPTION - Weight Plate, 15 lbs (6.8kg), Upgraded 250 lb Weight Stack w/ 18 each #21 Plates	20
DFT-022	Roll Pin, for Selector Rod to Top Plate, 10mm x 50mm L	2
DFT-023	Guide Rod Holder, Plastic	4
DFT-024	Top Plate	2
DFT-025	Selector Pin w/ Lanyard, Aluminum - BLUE	2
DFT-026	Stopper, Rubber, for Pulley Block on Weight Stack	2
DFT-027	Handle Cover, Long, $\phi 24 \times \delta 5 \times 325\text{mm}$	2
DFT-028	Handle Cover, Short, $\phi 24 \times \delta 5 \times 195\text{mm}$	2
DFT-029	L-Shaped Plate for Cable Guide on Upper Pulley	2
DFT-030	Snap Hook	4
DFT-031	Edge Banding for Top Connecting Frame w/ Bookrack & Accessory Holder	1
DFT-032	Cable Link Clip	2
DFT-033	Cable, 275-3/4" (7,005mm) L	2
DFT-034	Top Guide Rod Holder Plate	2
DFT-035	Cable Stopper Shell for End of Cable	2
DFT-036	Steel Shaft for End of #33 Cable Connection	2
DFT-037	Hook for Accessories	8

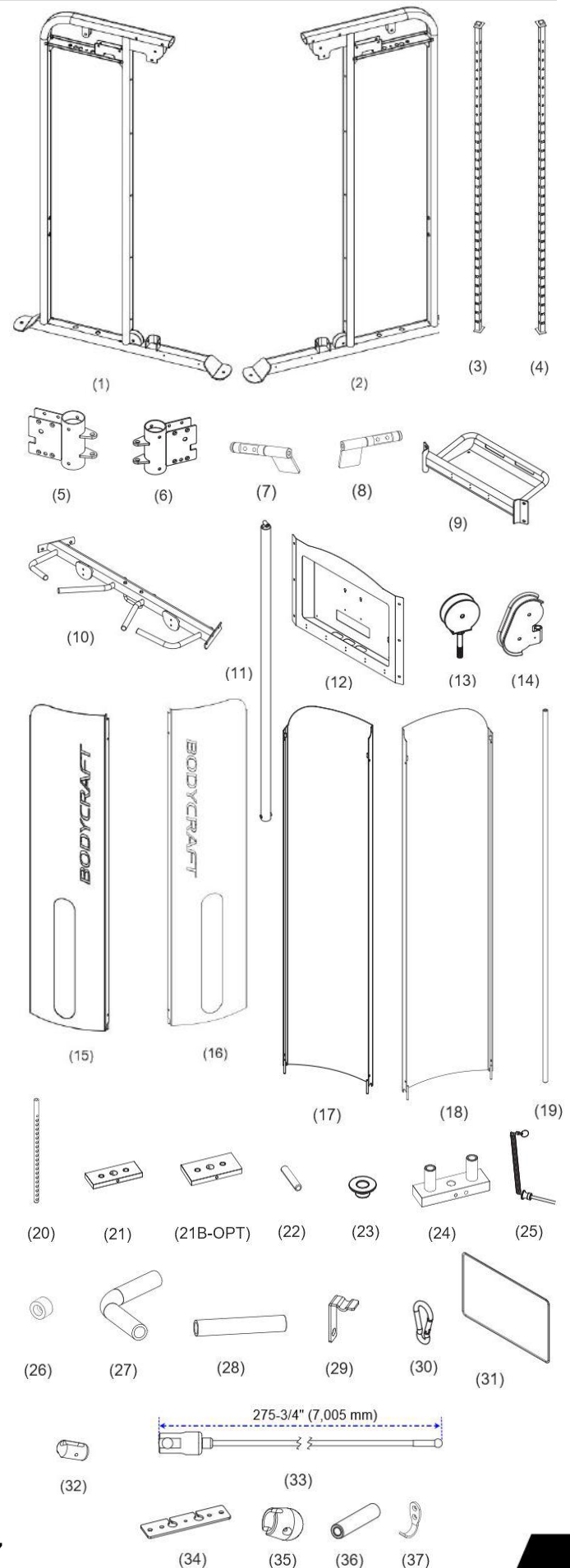

**NOTE:** Parts are not to scale

# Detailed Parts List, DFT

Part #	Detailed Parts list	QTY
DFT-038	Pulley, Aluminum, 90mm (3-1/2") x $\delta$ 26mm ID	4
DFT-039	Pulley, Nylon, 90mm (3-1/2") x $\delta$ 26mm ID	12
DFT-040	Foot Pad, Rubber	4
DFT-041	Frame Protection Pad, PVC, 220mm x 118mm	2
DFT-042	Locking Pin Bracket	2
DFT-043	Adjustment Release Handle	2
DFT-044	Snap Ring, 9mm x 1mm	2
DFT-045	Pull Release Axle Pin, $\phi$ 10.5mm x 66mm	2
DFT-046	Aluminum Retaining Ring - BLUE	4
DFT-047	Inner Slided Sleeve, Round	4
DFT-048	Rock Climbing Grip, Rt Side - BLUE	1
DFT-049	Rock Climbing Grip, Lt Side - BLUE	1
DFT-050	End Cap, Aluminum, for Chin Bar Multi-Grips w/ recessed center hole - BLUE w/ BC logo	4
DFT-051	Bearing, Steel, $\phi$ 12.7mm x $\phi$ 16 x $\phi$ 22	4
DFT-052	Rubber Pad, placed on the Bottom Connecting Frame	1
DFT-053	Wearpad, Upper for Pulley Height Adjuster	2
DFT-054	Wearpad, Lower for Pulley Height Adjuster	2
DFT-055	Compression Spring, 38mm FL, 13mm OD, 1.2mm WD	2
DFT-056	Accessory, Chain, 19.7" L	2
DFT-057	Protector Edge Stip for Weight Stack Front Cover	2
DFT-058	Snap Ring , 12mm for Lock Adjusting Lever Shaft	4
DFT-059	Foot Pad, Rectangle, Rubber for supporting the Weight Stack on both Main Frames	2
DFT-060	Rubber Stopper, Round for Rotating Pulley Holder	4
DFT-061	Rubber Cushion for Weight Stack	8
DFT-062	Plug, Square, 25mm x 25mm	4
DFT-063	Plug, Elliptical, PT80 x 40mm x $\delta$ 2.5, Plastic - BLK	2
DFT-064	Sticker Set for Weight Stack, for 200 lb or 250 lb Stacks	2
DFT-065	Accessory, Long Strap, 1,300mm L	1
DFT-066	Accessory, Ankle Cuff (Leg Strap)	1
DFT-067	Accessory, Long Bar, 1,010mm L	1
DFT-068	Accessory, Short Bar, 365mm L	1
DFT-069	Accessory, Single Handle	2
DFT-070	Accessory, Nylon Triceps Rope	1
DFT-071	Bolt, Hex Head, 3/8" x 1" L	4
DFT-072	Bolt, Hex Head, 3/8" x 2" L	14
DFT-073	Bolt, Hex Head, 3/8" x 2-1/2" L	4
DFT-074	Bolt, Hex Head, 3/8" x 3-1/4" L	2
DFT-075	Bolt, Hex Head, 3/8" x 4" L	4
DFT-076	Bolt, Hex Head, 1/2" x 3-1/4" L	2

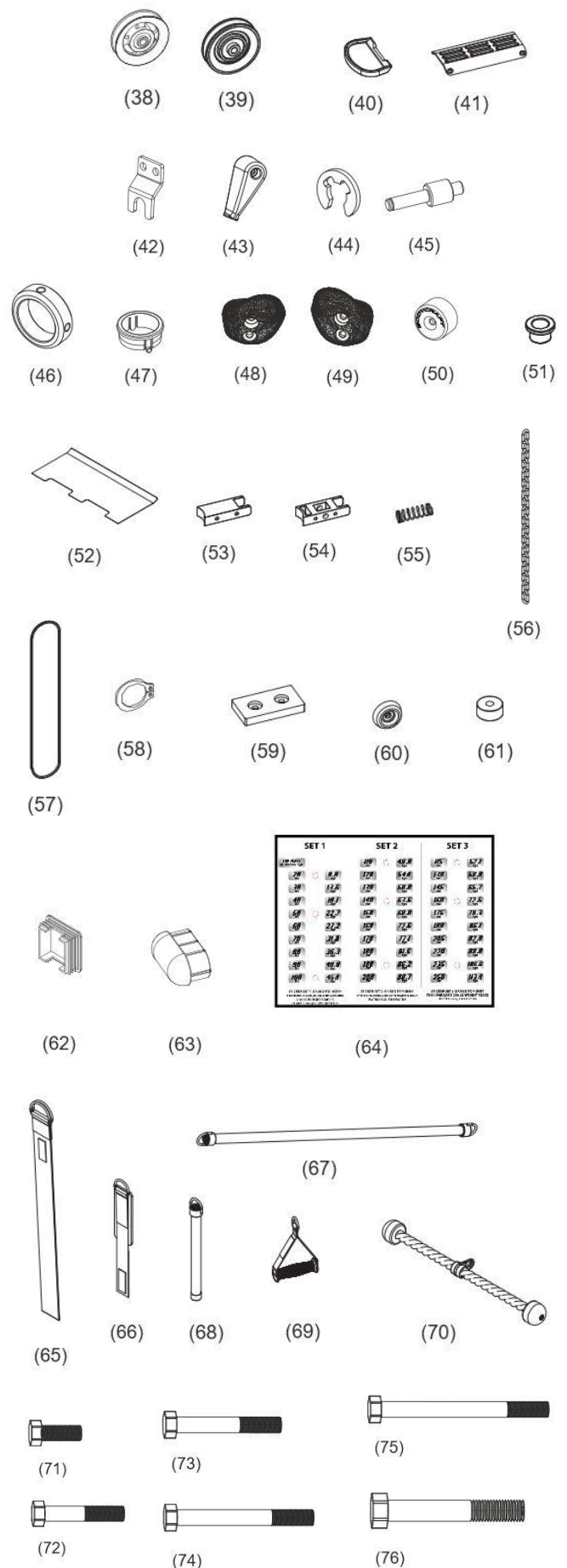

**NOTE:** Parts are not to scale

# Detailed Parts List, DFT

Part #	Detailed Parts list	QTY
DFT-077	Screw, Cross Recessed Countersunk Head, #10-32UNF*1-1/8"	2
DFT-078	Screw, Cross Recessed Pan Head, M6 x 12mm L	16
DFT-079	Screw, Hex Recessed Countersunk Head, M4 x 12mm L	16
DFT-080	Screw, Hex Recessed Countersunk Head, 1/4" x 3/4" L	016
DFT-081	Screw, Inner Hex, M5 x 4mm L	8
DFT-082	Bolt, Hex Recessed Flat Head, M6 x 12mm L	018
DFT-083	Bolt, Hex Recessed Flat Head, M8 x 16mm L	4
DFT-084	Screw, Hex Recessed Flat Head, 3/8" x 1" L	12
DFT-085	Screw, Hex Recessed Flat Head, M4 x 8mm L	4
DFT-086	Bolt, Hex Recessed Flat Head, M8 x 20mm L	2
DFT-087	Washer, Arc, 3/8"	8
DFT-088	Washer, Spring, φ6mm	14
DFT-089	Washer, Spring, 1/2"	2
DFT-090	Washer, Spring, 3/8"	16
DFT-091	Washer, Flat, φ6mm	10
DFT-092	Washer, Flat, φ8mm	8
DFT-093	Washer, Flat, 3/8"	56
DFT-094	Washer, Flat, 1/2"	4
DFT-095	Nut, Nylon Lock, Thin, 1/2"	2
DFT-096	Nut, Nylon Lock, 3/8"	24
DFT-097	Nut, Nylon Lock, M4	10
DFT-098	Nut, Hex, 1/2"	2
DFT-099	Wrench, Hex, 4mm	1
DFT-100	Wrench, Hex, 7/32"	1
DFT-101	Screw, Cross Recessed Pan Head, M4 x 5mm L	4
DFT-102	Silicone Lube Bottle, for Guide Rods	1
DFT-103	Poster - Exercise Guide	1
DFT-104	Warning Label - Fasten the machine to the floor	1
DFT-105	Warning Label - Please utilize this equipment solely for its designated purpose	1
DFT-106	Warning Label - Be aware of moving parts	1
DFT-107	Warning Label - Master Rules and Precautions	1
DFT-108	Warning Label - Do not at any time lean against framework	1
DFT-109	Warning Label - Pinch Point, Vertical	2
DFT-110	Warning Label - Pinch Point, Horizontal	2
DFT-111	Label - Maintenance Schedule	1
DFT-112	Label - California Proposition 65 Warning	1
DFT-113	Label - Serial Number	1
DFT-114	Label - QR code	1
DFT-115	Label - Trademark 1#	1
DFT-116	Label - Trademark 2#	1
DFT-117	Screw, Hex Recessed Countersunk Head, M6 x 16mm L	4

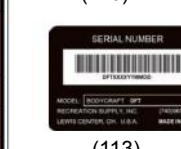
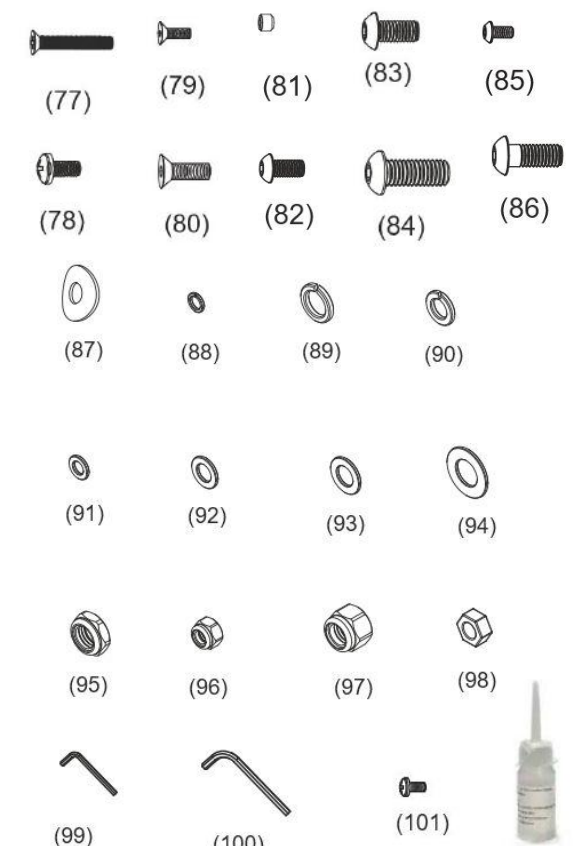

NOTE: Parts are not to scale



## ***Required Information BEFORE Initiating a Service Case***

***The following information is needed to help expedite troubleshooting and to ensure the correct part(s) are sent if needed for a repair:***

- 1) What product / model # do you have?
- 2) Unit serial number?
- 3) Installed by a dealer or direct sale?
- 4) Date of installation?
- 5) Date of service issue?
- 6) Complaint or problem, including any Error Codes?
- 7) Cardio &/or Connect 22 tablet, has the software been updated?
- 8) What part(s) are being requested?
- 9) Any picture or video will help with troubleshooting or exact part(s) needed.

## Product Warranty - Strength Equipment

### VALID FOR USA AND CANADA ONLY

(Please consult with your local distributor for warranty info specific to your region).

BODYCRAFT warrants its products to be free of defects in materials and workmanship for the time stated below to the original purchaser.

**Register your product within 30 days of purchase at [www.bodycraft.com](http://www.bodycraft.com) or call 800-990-5556**

#### **This warranty is valid only in accordance with the following conditions:**

The warranty begins on the original purchase date at retail and ends when the original owner disposes of it, either through sale, gift, or otherwise. This warranty is not transferable and is only valid to the original purchaser.

This warranty is available only for purchases made within and the original purchaser currently residing in the USA and Canada. Please consult with your local distributor for warranty information specific to your region. The product must have been registered within 30 days of the original purchase date or supply proof of purchase to validate warranty (original sales invoice).

This warranty does not extend to any losses or damages due to accident, misuse, abuse, neglect, negligence, unauthorized modification or alteration, use beyond rated capacity, unsuitable power sources or environmental conditions, water, tampering, cosmetic damages, or improper installation, handling, repair, maintenance, or application, or lack of proper maintenance.

If the item exhibits such a defect, BODYCRAFT will, at its option, repair or replace it without cost for parts. Shipping and handling charges may apply. (BODYCRAFT may require return of the part(s) or photographic evidence of the damaged part(s) prior to replacement.) Serial number is required.

Parts repaired or replaced will be warranted for the remainder of the original warranty period only.

<b><u>Warranty for Strength Equipment:</u></b>	<b><u>Residential Use</u></b>	<b><u>Commercial Use</u></b>
<b>Frame:</b>	Lifetime	10 years
<b>Structural Moving Parts:</b>	10 years	5 years
<b>Roller Parts:</b>	10 years	3 years
<b>Cables, Upholstery &amp; Accessories:</b>	10 years	2 years
<b>Labor:</b>	90 days	90 days

#### **This warranty excludes the following:**

1. The warranty does not cover normal maintenance or labor charges unless labor terms are listed above.
2. Normal cosmetic wear on parts such as paint, seat coverings, foot rails, labels and logos.
3. Any accessories not included in the original packaging.
4. Warranty does not cover normal wear and tear.

\* This warranty is in lieu of all warranties, expressed or implied, and/or all other obligations or liabilities on our part, and we neither assume nor authorize any person to assume for us any other obligation or liability in connection with the sale of your BODYCRAFT product. Under no circumstances shall we be liable by virtue of this warranty or otherwise for damage to any person or property whatsoever for any special, indirect, incidental, secondary or consequential damage of any nature whatsoever arising out of the use or inability to use the BODYCRAFT product.

Register your product's warranty at [www.bodycraft.com/product-registration.html](http://www.bodycraft.com/product-registration.html)

## Warranty Registration - Strength

Thank you for purchasing a BODYCRAFT product. To validate the product warranty the fast and easy way, please go on-line now to <https://www.bodycraft.com/product-registration.html> and register your product. The information you provide will never be distributed to any other individuals or agencies for any purpose. If you prefer to mail your warranty card, have the owner of the product complete the information below and return it to BODYCRAFT within 30 days from the date of equipment installation.

**Please Note: Failure to register this product may result in no servicing or authorization of parts to be shipped.**

To mail your warranty information, please fill in the information below and mail to: Service Dept., BODYCRAFT , 7699 Green Meadows Dr. Lewis Center, Ohio 43035 (or save postage and register online at <https://www.bodycraft.com/product-registration.html> )

### WARRANTY REGISTRATION

**PLEASE PROVIDE SERIAL NUMBER(S) BELOW, REQUIRED FOR WARRANTY REGISTRATION:**

BASE UNIT SERIAL NUMBER:

OPTIONS SERIAL NUMBER(S):

Model Type: \_\_\_\_\_

Date of Purchase \_\_\_\_\_

Your Company Name \_\_\_\_\_

Contact First Name \_\_\_\_\_

Contact Last Name \_\_\_\_\_

Address \_\_\_\_\_

City \_\_\_\_\_ State \_\_\_\_\_ ZIP \_\_\_\_\_

Email Address \_\_\_\_\_ Website \_\_\_\_\_

Phone \_\_\_\_\_ Fax \_\_\_\_\_

**1. Where did you first learn about BODYCRAFT?**

- a. Dealer                       b. Website  
 c. Advertisement           d. Referral  
 e. Current Customer         f. Other \_\_\_\_\_

**2. Why did you purchase a BODYCRAFT product?**

- a. Design/Appearance       b. Dealer Suggestion  
 c. Price/Value                 d. Quality Construction  
 e. Performance               f. BODYCRAFT Reputation  
 g. Other: \_\_\_\_\_

**3. Please indicate your type of facility:**

- a. Apartment/Condo         b. Corporate Fitness Center  
 c. Municipality               d. Health Club/Gym/Spa  
 e. Hotel/Resort               f. Military Base  
 g. Student Rec Center       h. Home

**4. What other types of equipment does your company or home currently own?**

- a. Treadmill                      Brand \_\_\_\_\_  
 b. Elliptical                      Brand \_\_\_\_\_  
 c. Bike/Indoor Cycle          Brand \_\_\_\_\_  
 d. Free Weights/Gym          Brand \_\_\_\_\_

**5. How many people use your facility on a daily basis?**

- a. <25                               b. 25-75  
 c. 76-150                           d. 150+

**6. Do you plan to purchase more fitness equipment in the next 6-12 months?**

Yes \_\_\_\_\_ No \_\_\_\_\_

**7. If you answered "yes" to question 6, what type do you plan to purchase?**

- Yes  
 a. Treadmill                       b. Elliptical  
 c. Bike/Indoor Cycle           d. Free Weights  
 e. Gym                               f. Other \_\_\_\_\_

**8. Would you recommend BODYCRAFT to other club or home owners?**

\_\_\_\_\_ No

**9. You are a valued BODYCRAFT customer and your suggestions allow us to continually improve your experience. Is there anything else you would like us to know? Please explain:**





800.990.5556  
SERVICE@BODYCRAFT.COM  
WWW.BODYCRAFT.COM



BODYCRAFT  
7699 GREEN MEADOWS DR.  
LEWIS CENTER, OHIO 43035